



Name \_\_\_\_\_

## 5<sup>th</sup> Grade Math Remote Learning Packet

### Week 32



---

Dear Educator,

My signature is proof that I have reviewed my scholar's work and supported him to the best of my ability to complete all assignments.

\_\_\_\_\_  
(Parent Signature)

\_\_\_\_\_  
(Date)

Parents please note that all academic packets are also available on our website at [www.brighterchoice.org](http://www.brighterchoice.org) under the heading "Remote Learning." All academic packet assignments are mandatory and must be completed by all scholars.



# Day # 1

**Mod 5 End of Mod SPA Assessment**

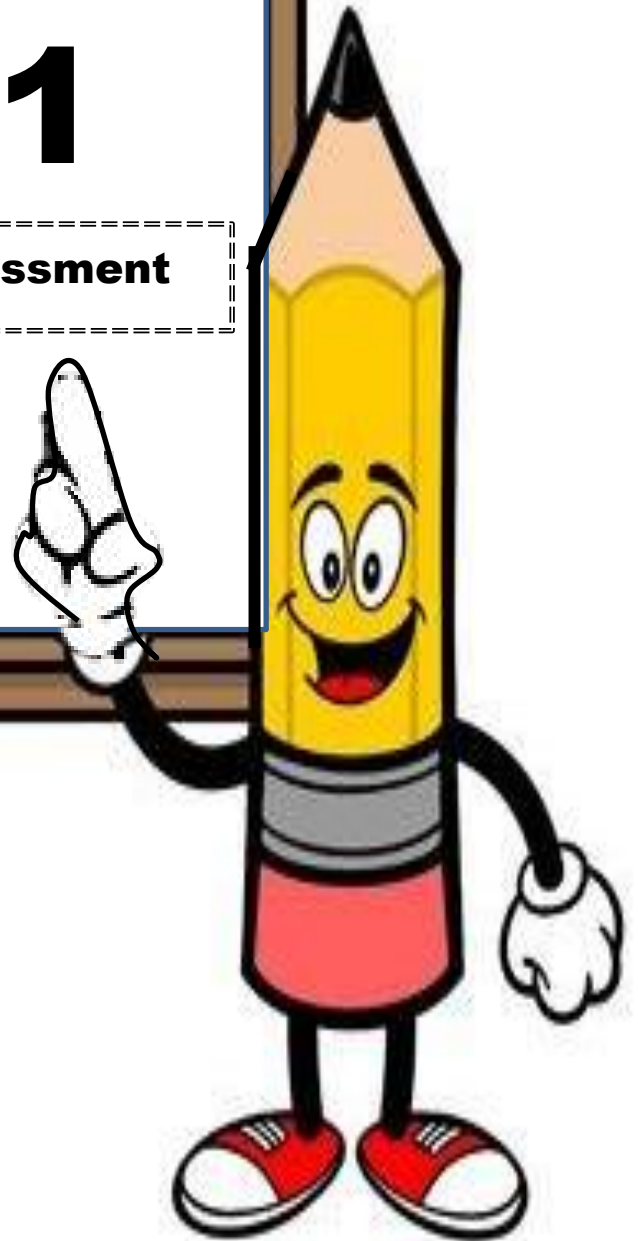

Name: \_\_\_\_\_ Week 32 Day 1 Date: \_\_\_\_\_

BCCS-Boys

Stanford MIT

**Module 5 End Module SPA Assessment****Directions: Make sure to show *all* your work and complete each part.****Good luck! ☺****Part I: Multiple Choice**

- \_\_\_\_\_ 1. What is the volume, in cubic centimeters, of the figure below?  
(5.MD.4)

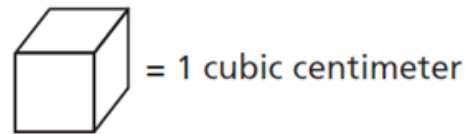
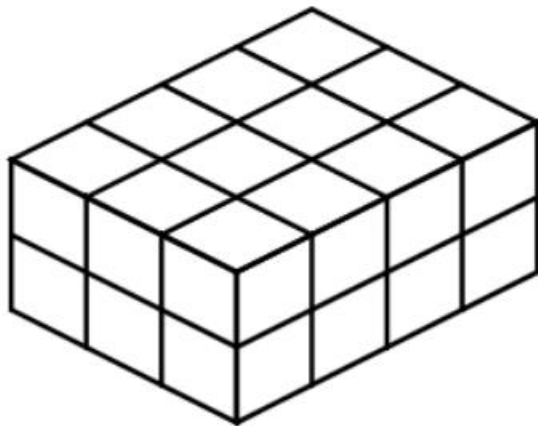

- A. 15
- B. 24
- C. 30
- D. 45

\_\_\_\_\_ 2. Which type of quadrilateral always has four right angles? (5.G.3)

- A. kite
- B. rectangle
- C. rhombus
- D. trapezoid

\_\_\_\_\_ 3. Rashad is filling a toy box that are each a unit cube in size. He filled the bottom layer of the toy box with 15 wooden blocks. He then stacked two more wooden blocks on top of the bottom layer. The partially filled toy box is shown below. (5.MD.5a)

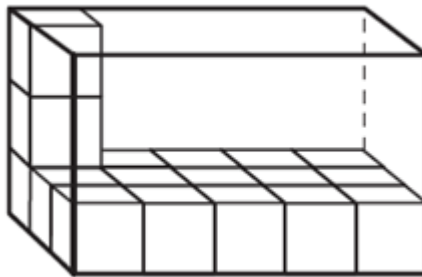

What is the total volume, in cubic units, of the toy box?

- A. 15
- B. 17
- C. 30
- D. 45

\_\_\_\_\_ 4. A swimming pool is shaped like a right rectangular prism. The pool is 36 feet long and 20 feet wide. What is the total amount of water, in cubic feet, needed to fill the pool to a depth of 4 feet? (5.MD.5b)

A. 800

B. 864

C. 2,880

D. 5,760

\_\_\_\_\_ 5. Which type of quadrilateral can have exactly 1 pair of parallel sides? (5.G.3)

A. rectangle

B. rhombus

C. square

D. trapezoid

6. In his math class Clark used unit cubes to build a right rectangular prism with a volume of 24 cubic units. The height of the prism was two units. Which figure could be the bottom layer of the prism? (5.MD.3a)

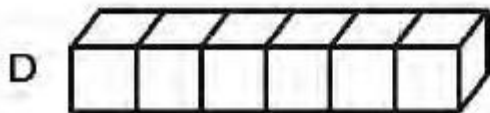
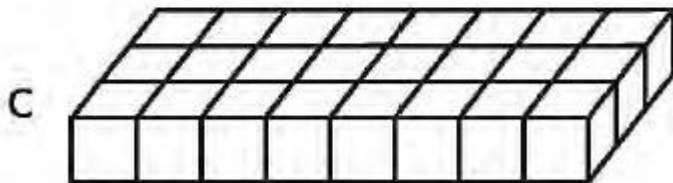
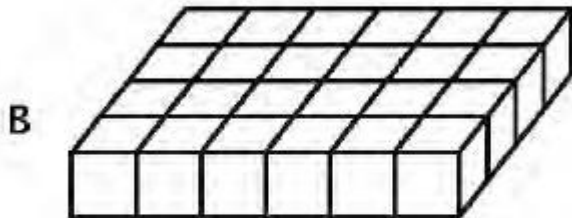
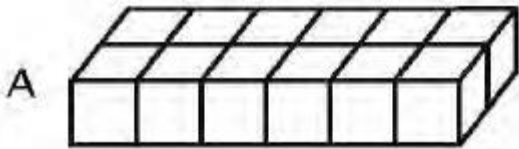

\_\_\_\_\_ 7. Which model shows one way to determine the area of a rectangle that is  $\frac{7}{10}$  meter long and  $\frac{3}{5}$  meter wide? (5.NF.4a)

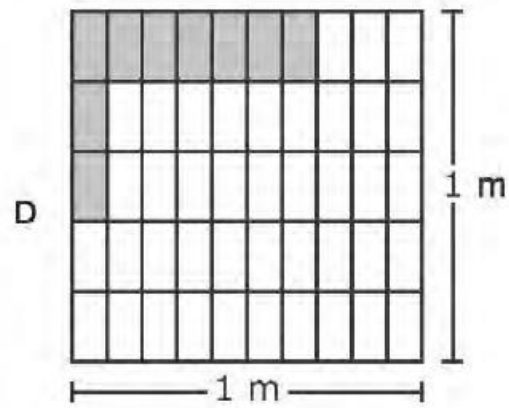
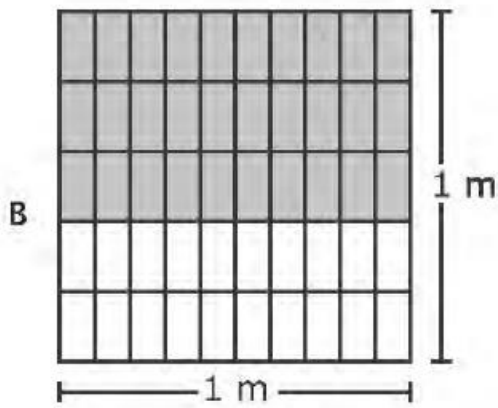
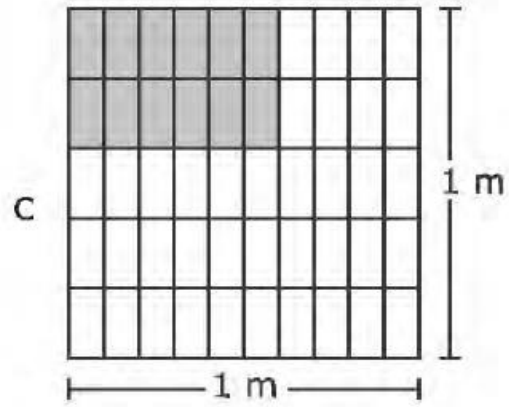
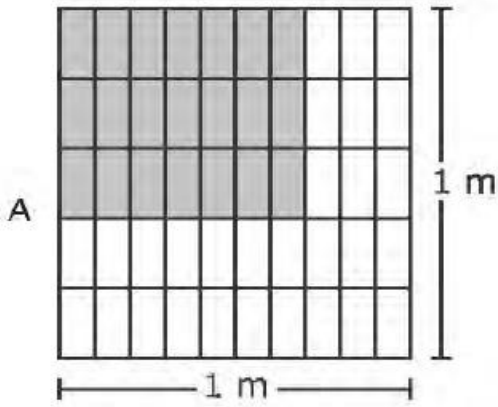

\_\_\_\_\_ 8. Which of these figures is a quadrilateral? (5.G.3)

A. triangle

B. trapezoid

C. octagon

D. pentagon

\_\_\_\_\_ 9. The figure below is made of unit cubes. (5.MD.4)

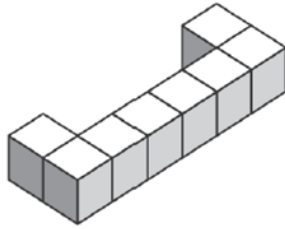

How many unit cubes need to be added to the figure so that it will have a total volume of 12 cubic units?

- A. 1
- B. 2
- C. 4
- D. 8



10. What is the area of the square below? (5.NF.4a)

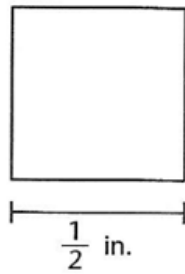

A.  $\frac{1}{8}$  square inch

B.  $\frac{1}{2}$  square inch

C.  $\frac{1}{4}$  square inch

D. 1 square inch

- \_\_\_\_\_ 11. Jack used cubes to make the right rectangular prism below.  
(5.MD.5a)

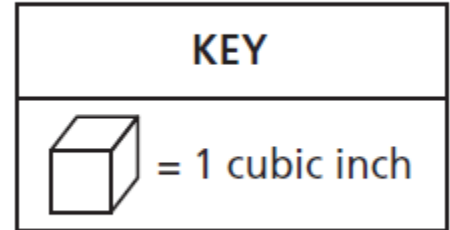
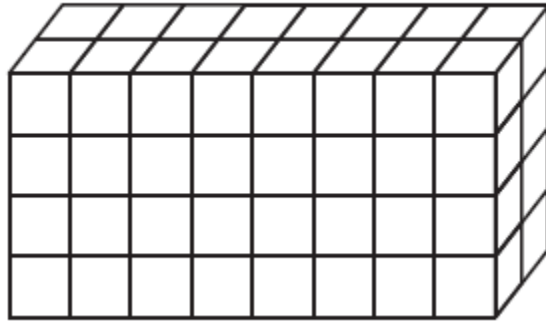

He then made a smaller right rectangular prism using  $\frac{1}{4}$  of the number of cubes. What was the volume, in cubic inches, of the smaller right rectangular prism?

- A. 8
- B. 13
- C. 16
- D. 64

12. The area of a rectangular prism is  $240 \text{ in}^2$ . If the height is 9 in, what is the volume? (5.MD.5b)

The volume is \_\_\_\_\_  $\text{in}^3$ .

13. What is the area, in square inches, of a rectangle with the dimensions shown in the diagram below? (5.NF.4a)

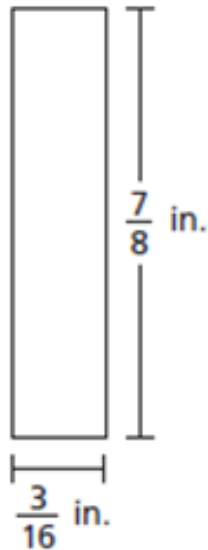

The area is \_\_\_\_\_  $\text{in}^2$ .

14. The two right rectangular prisms below have different volumes. (5.MD.5a)

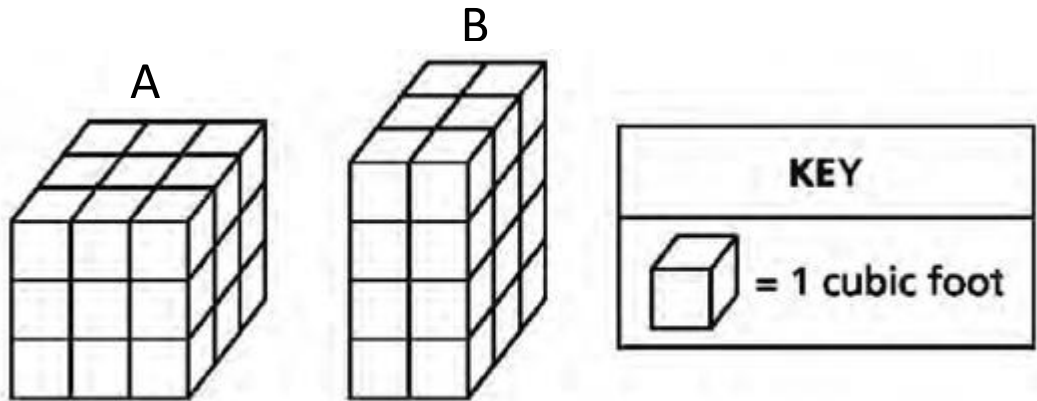

Find the volume of each prism.

A = \_\_\_\_\_ cubic feet

B = \_\_\_\_\_ cubic feet

What is the difference, in volume, in cubic feet, of the two volumes?

Answer \_\_\_\_\_ cubic feet



# Day # 2

**NYS Math Review Packet 1**

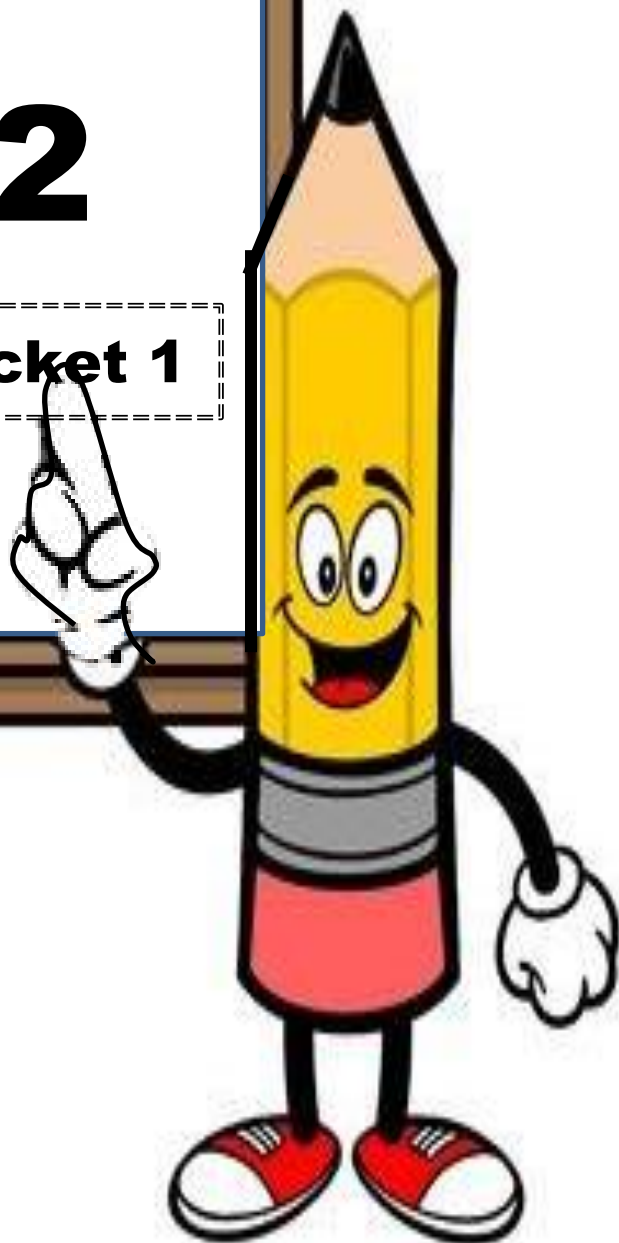

Name: \_\_\_\_\_ Week 32 Day 2 Date: \_\_\_\_\_

BCCS-Boys

Stanford MIT

**Do Now**

Which expression means the same as the phrase below?

Subtract 3 from the product of 8 and 5

- A**  $(5 \times 8) + 3$
- B**  $(5 \times 8) - 3$
- C**  $5 \times (8 - 3)$
- D**  $5 \times (8 + 3)$
- 

What is 0.1829 rounded to the tenths place?

- A. 0.2
- B. 0.19
- C. 0.18
- D. 0.184
-

**NYS Math Review Packet 1:**

**Place Value, Decimals, and PEMDAS Review**

1. A number is given below.

136.25

In a different number, the 6 represents a value which is one-tenth of the value of the 6 in the number above. What value is represented by the 6 in the other number?

- A six hundredths
- B six tenths
- C six ones
- D six tens

2. Which expression is equivalent to 100,000?

- A  $10^4$
- B  $10^5$
- C  $10^6$
- D  $10^7$

3. Which expression represents the phrase "4 times the sum of 9 and 6"?

- A  $4 \times (9 + 6)$
- B  $4 \times 9 + 6$
- C  $9 + 6 \times 4$
- D  $9 + (6 \times 4)$

4. Which decimal best represents the location of point X on the number line below?

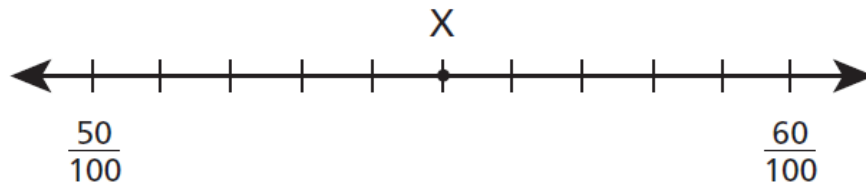

- A** 0.5  
**B** 0.55  
**C** 0.56  
**D** 0.6
5. Which decimal makes the number sentence true?

$$0.27 > \underline{\quad ? \quad}$$

- A** 0.4  
**B** 0.26  
**C** 0.3  
**D** 0.28
6. Which equation correctly shows the relationship between the numbers 2,560 and 256?

- A**  $2,560 = 1,000 \times (2 + 5 + 6)$   
**B**  $2,560 = 10 \times (2 + 5 + 6)$   
**C**  $2,560 = 10 \times (200 + 50 + 6)$   
**D**  $2,560 = \frac{1}{10} \times (200 + 50 + 6)$



7. Which expression is equivalent to 32?

**A**  $(30 + 6) \div 3$

**B**  $2 \times (9 + 7)$

**C**  $9 \times (3 + 5)$

**D**  $6 + 2 \times 4$

8. The distance from Greg's house to Tanya's house is  $\frac{7}{10}$  of a mile.

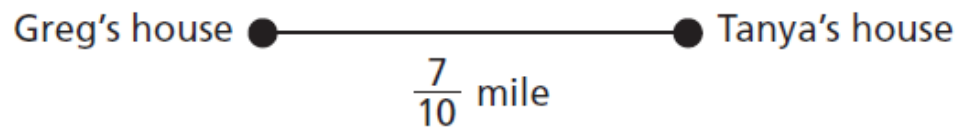

Which number correctly shows the number of miles as a decimal?

**A** 0.07

**B** 0.7

**C** 7.0

**D** 7.10

9. Which decimal is equivalent to  $\frac{41}{100}$ ?

**A** 41.0

**B** 4.10

**C** 0.41

**D** 0.041

10. What is the value of the expression below?

$$8 + 24 \div (2 \times 6) - 4$$

A 92

B 76

C 11

D 6

11. Which expression is equivalent to 83,120 in expanded form using powers of 10?

A  $(8 \times 10^5) + (3 \times 10^4) + (1 \times 10^3) + (2 \times 10^2)$

B  $(8 \times 10^4) + (3 \times 10^3) + (1 \times 10^3) + (2 \times 10^2)$

C  $(8 \times 10^4) + (3 \times 10^3) + (1 \times 10^2) + (2 \times 10^1)$

D  $(8 \times 10^1) + (3 \times 10^1) + (1 \times 10^1) + (2 \times 10^1)$

12. What part of the expression below should be calculated first?

$$8 + \{22 \times [15 + (14 \times 2)]\}$$

A  $8 + 22$

B  $22 \times 15$

C  $14 \times 2$

D  $15 + 14$

13. What number is equivalent to the expanded form shown below?

$$(2 \times 100) + (3 \times 1) + \left(4 \times \frac{1}{10}\right) + \left(3 \times \frac{1}{1,000}\right)$$

- A 203.043
- B 203.403
- C 230.430
- D 230.403

14. Which phrase is represented by the expression  $5 \times (36 + 9)$ ?

- A the product of 36 and 5, increased by 9
- B the product of 36 and 9, multiplied by 5
- C the sum of 36 and 9, multiplied by 5
- D the sum of 36 and 5, increased by 9

15. The value of the digit in the hundreds place in the number 653,841 is  $\frac{1}{10}$  the value of the digit in the thousands place in which number?

- A 748,917
- B 749,817
- C 784,917
- D 797,481

16. What is the value of 0.1561 rounded to the nearest tenth?

- A 0.15
- B 0.16
- C 0.1
- D 0.2

17. The decimal grids below are shaded to model an expression.

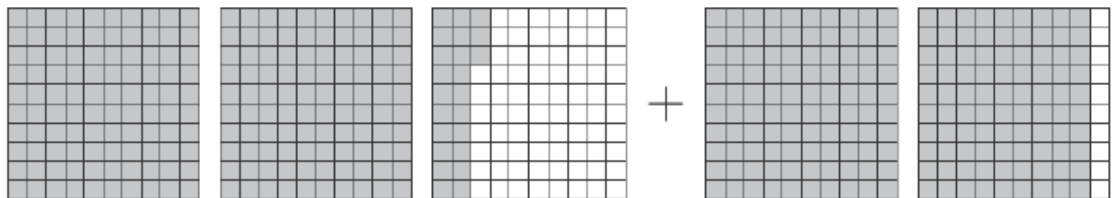

What is the value of the expression modeled by the decimal grids?

- A 3.29
  - B 3.32
  - C 4.10
  - D 4.13
18. Which expression is equal to "add 10 and 32, and then multiply by 3"?
- A  $3 \times (10 \times 32)$
  - B  $(10 + 32) \div 3$
  - C  $3 \times (10 + 32)$
  - D  $3 + (10 \times 32)$

19. Point K is shown on the number line below.

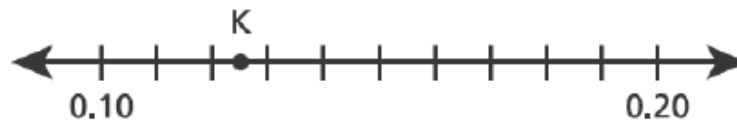

Which number sentence **best** describes the value represented by point K?

- A  $K > 0.13$
- B  $K < 0.13$
- C  $K = 0.15$
- D  $K = 0.35$

20. Which decimal makes this number sentence true?

$$0.58 > \underline{\hspace{1cm}}$$

- A 0.5
- B 0.59
- C 0.589
- D 0.6

21. What is the value of the expression below?

$$40 \div 2 + (2 \times 5) - 8$$

- A. 10
- B. 26
- C. 22
- D. 30

## Problem Set

Which number sentence is true?

A.  $0.6 > 0.55$

B.  $0.5 > 0.55$

C.  $0.5 < 0.04$

D.  $0.45 > 0.46$

---

Which expression is equivalent to 62,340?

A.  $(6 \times 10^5) + (2 \times 10^4) + (3 \times 10^3) + (4 \times 10^2)$

B.  $(6 \times 10^5) + (2 \times 10^4) + (3 \times 10^3) + (8 \times 10^1)$

C.  $(6 \times 10^4) + (2 \times 10^3) + (3 \times 10^2) + (4 \times 10^1)$

D.  $(6 \times 10^3) + (2 \times 10^2) + (3 \times 10^2) + (4 \times 10^1)$

---

The value of the digit 4 in 24,601 is how many times greater than the value of the digit 4 in 437?

A. 1

B. 10

C. 100

D. 1,000

## Application Problem

Which expression has the same value as 743.216?

- A.  $(7 \times 100) + (4 \times 10) + (3 \times 1) + (2 \times 10) + (1 \times 100) + (6 \times 1,000)$
- B.  $(7 \times 100) + (4 \times 10) + (3 \times 1) + \left(2 \times \frac{1}{1}\right) + \left(1 \times \frac{1}{10}\right) + \left(6 \times \frac{1}{100}\right)$
- C.  $(7 \times 100) + (4 \times 10) + (3 \times 1) + \left(2 \times \frac{1}{100}\right) + \left(1 \times \frac{1}{1,000}\right) + \left(6 \times \frac{1}{10,000}\right)$
- D.  $(7 \times 100) + (4 \times 10) + (3 \times 1) + \left(2 \times \frac{1}{10}\right) + \left(1 \times \frac{1}{100}\right) + \left(6 \times \frac{1}{1,000}\right)$

## Exit Ticket

Light from the Sun can travel a million miles in 5.368 seconds. How many seconds is that, rounded to the nearest tenth of a second?

- A** 5.36 seconds
- B** 5.37 seconds
- C** 5.3 seconds
- D** 5.4 seconds



# Day # 3

**NYS Math Review Packet 2**

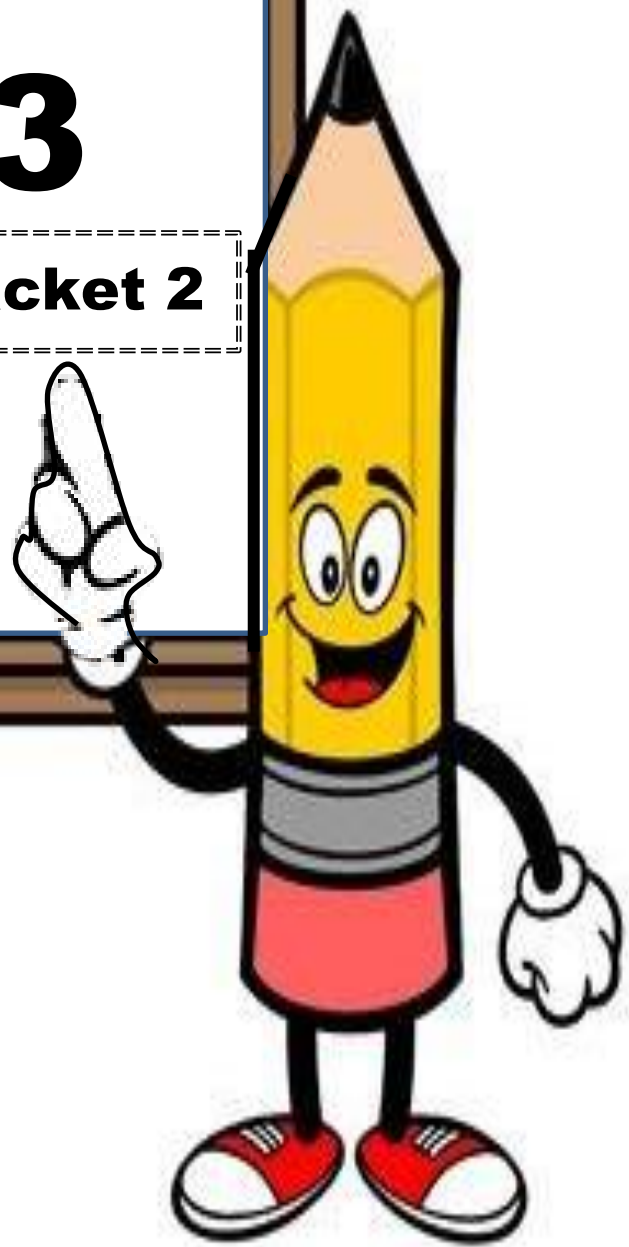



Name: \_\_\_\_\_ Week 32 Day 3 Date: \_\_\_\_\_

BCCS-Boys

Stanford MIT

**Do Now**

What is the value of the expression below?

$$1,536 \div 24$$

- A** 57
- B** 64
- C** 65
- D** 68

# 5th Grade Mathematics Reference Sheet

---

1 cm = 10 mm  
1,000 m

1 m = 100 cm  
liters

1m = 1,000 mm

1km = 1,000 m  
5,280 ft

yd

1 g = 1,000 mg

1 kg = 1,000 g

1lb = 16 oz

1 ton = 2,000 lb

1 cup = 8 fluid ounces  
60 min

1 pint = 2 cups  
hr

1 quart = 2 pints  
months

1 gallon = 4 quarts  
days

1 liter =

1 kl = 1,000

1 mile =

1 mile = 1,760

1 ft = 12 in

1 yd = 3 ft

1 yd = 36 in

1 min = 60 sec

1 hr =

1 day = 24

1 year = 12

1 year = 365

1 week = 7 days

1 month = 31, 30, or  
28 days

**NYS Math Review Packet 2:**  
**Word Problems and Conversion Review**

1. What number goes in the blank to make the statement below true?

$$3,840 \text{ ounces} = \underline{\hspace{2cm}} \text{ pounds}$$

- A** 24
- B** 240
- C** 480
- D** 61,440
2. Lincoln had 2 books in his backpack. One book had a mass of 3 pounds 7 ounces, and the other book had a mass of 2 pounds 10 ounces. What was the total mass, in ounces, of the books?
- A** 60
- B** 77
- C** 80
- D** 97
3. Christopher wants to buy a notebook for \$2.15, a pack of glue sticks for \$5.08, and a pack of pens for \$3.08. What is the total cost of the three items Christopher wants to buy?
- A** \$10.75
- B** \$10.31
- C** \$10.23
- D** \$10.11

4. Michele is 52 inches tall. Her father is 6 feet 3 inches tall. Exactly how many inches taller is Michele's father than Michele?

**A** 11

**B** 13

**C** 23

**D** 25

5. A box contains 512 grams of cereal. One serving of cereal is 56 grams. How many servings of cereal does the box contain?

**A**  $9\frac{1}{4}$

**B**  $9\frac{1}{8}$

**C**  $9\frac{8}{56}$

**D**  $9\frac{8}{512}$

6. Nellie has a watering can that contains 20 cups of water. She pours one quart of water on each plant in her yard. If Nellie uses all of the water in the watering can, how many plants does she water?

**A** 4

**B** 5

**C** 10

**D** 80

7. Pax wants to make fruit punch for a party using the recipe below.

| <b>Fruit Punch</b>    |
|-----------------------|
| 1.25 L orange juice   |
| 2.5 L cranberry juice |
| 1 L ginger ale        |

He will make three times the amount of fruit punch listed in the recipe. What is the total amount of fruit punch, in liters, that Pax will make?

- A 4.53
- B 4.75
- C 12.90
- D 14.25
8. Bettina spent \$75 on 5 shirts that each cost the same price. Three of the shirts were red. Which expression represents the total cost of the red shirts?
- A  $75 \times \frac{3}{5}$
- B  $75 \times \frac{5}{3}$
- C  $\frac{75}{5} \times \frac{1}{3}$
- D  $\frac{75}{3} \times \frac{1}{5}$
9. Mr. Hinckley owns 83 acres of land. He divides the land into eight equal sections to sell to eight buyers. Which phrase describes how much land, in acres, each buyer will receive?
- A more than 9 and less than 10
- B more than 10 and less than 11
- C more than 11 and less than 12
- D more than 12 and less than 13

10. The table below lists the capacity, in quarts, of four different fish tanks at a pet store.

**FISH TANK CAPACITY**

| Fish Tank | Capacity (quarts) |
|-----------|-------------------|
| Pacific   | 240               |
| Fresh     | 15                |
| Tropic    | 120               |
| Bahama    | 60                |

Which fish tank has a capacity of 60 gallons?

- A Pacific
- B Fresh
- C Tropic
- D Bahama

11. The table shows the number of computers donated to a school by each of 4 companies.

**COMPUTERS DONATED TO A SCHOOL**

| Company | Number of Computers |
|---------|---------------------|
| A       | 25                  |
| B       | 40                  |
| C       | 25                  |
| D       | 30                  |

All the donated computers were shared equally by 5 classrooms. Which expression represents the number of computers each classroom received?

- A  $120 \times \frac{5}{4}$
- B  $120 \times \frac{1}{4}$
- C  $120 \times \frac{4}{5}$
- D  $120 \times \frac{1}{5}$

12. Which measurement is equivalent to 3 meters?

- A 9 centimeters
- B 36 centimeters
- C 100 centimeters
- D 300 centimeters

13. Mia buys 5 yards of ribbon to make bracelets. She needs 18 inches of ribbon to make 1 bracelet. How many bracelets can Mia make if she uses all the ribbon she buys?

- A 90
- B 10
- C 3
- D 2

14. What is the length of the beetle shown below, in centimeters?

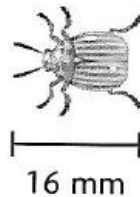

- A 0.16 cm
- B 1.6 cm
- C 160 cm
- D 1,600 cm

## Problem Set

A club with 420 members is going on a bus trip. Each bus can hold 30 passengers. How many buses did the club need?

- A. 11
  - B. 14
  - C. 110
  - D. 140
- 

Carol walked 1.5 kilometers. How many meters did she walk?

- A. 15
- B. 150
- C. 1,500
- D. 15,000



### **Application Problem**

A baker bought a bottle of vanilla extract measuring 1 liter. He needs it for a cake recipe that requires 20 milliliters of vanilla extract. How many times can the baker make this before he runs out of vanilla extract?

- A. 5 times
- B. 20 times
- C. 50 times
- D. 500 times

### **Exit Ticket**

There are 12 baseball cards in a case. How many baseballs are there in 18 cases?

- A. 30
- B. 108
- C. 116
- D. 216



# Day # 4

**NYS Math Review Packet 3**

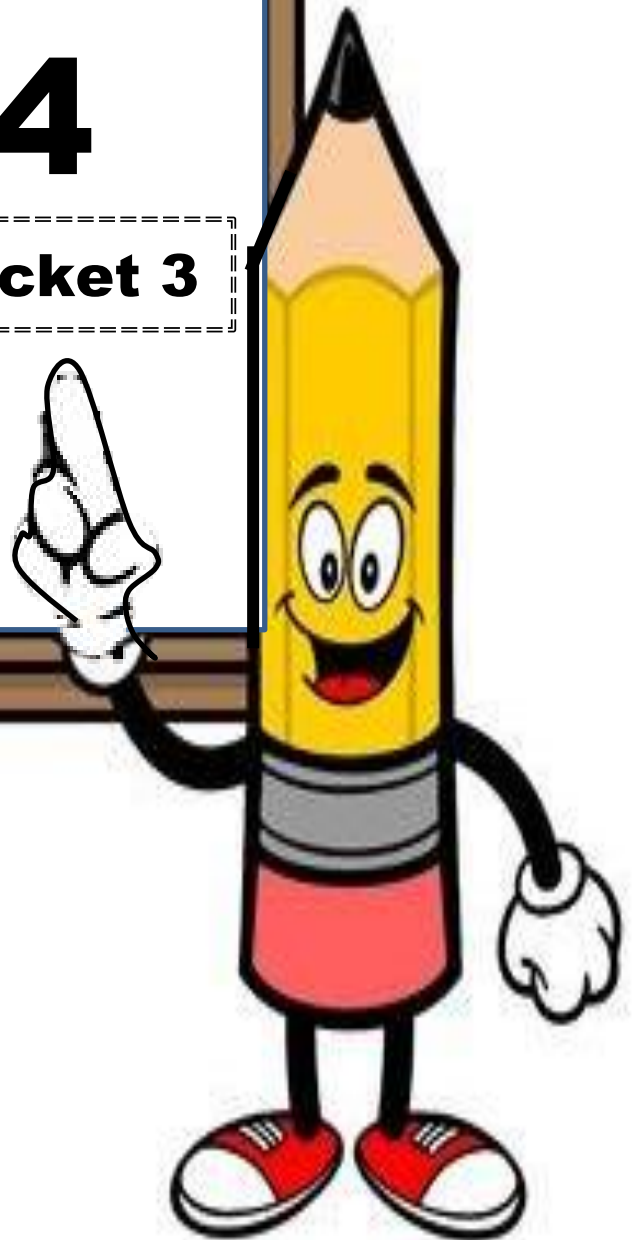

Name: \_\_\_\_\_ Week 32 Day 4 Date: \_\_\_\_\_

BCCS-Boys

Stanford MIT

**Do Now**

What is the value of  $\frac{2}{5} + \frac{3}{7}$ ?

**A**  $\frac{6}{35}$

**B**  $\frac{5}{12}$

**C**  $\frac{6}{12}$

**D**  $\frac{29}{35}$

**NYS Math Review Packet 3:**

**Fractions Review**

1. A recipe for 1 batch of muffins included  $\frac{2}{3}$  cup of raisins. Ina made  $2\frac{1}{2}$  batches of muffins. How many cups of raisins did she use?
- A**  $1\frac{4}{6}$
- B**  $1\frac{5}{6}$
- C**  $2\frac{2}{6}$
- D**  $3\frac{1}{6}$
- 
2. Mani, James, and Isidro equally shared  $\frac{1}{2}$  of a pie. Which fraction of the whole pie did each of them receive?
- A**  $\frac{1}{6}$
- B**  $\frac{1}{5}$
- C**  $\frac{2}{3}$
- D**  $\frac{3}{2}$

3. Austin collected  $30\frac{9}{10}$  kilograms of glass for recycling. Exactly  $\frac{2}{3}$  of the glass he collected was blue. What was the total amount, in kilograms, of blue glass Austin collected?

**A**  $20\frac{3}{5}$

**B**  $27\frac{2}{3}$

**C**  $30\frac{3}{5}$

**D**  $30\frac{11}{13}$

4. Clark made a model of his house. His house is  $30\frac{1}{2}$  feet long. The dimensions of the model were  $\frac{1}{25}$  the dimensions of Clark's actual home. What is the length, in feet, of the model?

**A**  $1\frac{10}{50}$

**B**  $1\frac{11}{50}$

**C**  $30\frac{23}{50}$

**D**  $30\frac{27}{50}$

5. Deb has a board that measures 5 feet in length. How many  $\frac{1}{4}$ -foot-long pieces can Deb cut from the board?

- A 1
- B 9
- C 10
- D 20

6. Equation 1:  $\frac{3}{10} + \frac{15}{100} = \frac{18}{100}$

Equation 2:  $\frac{4}{10} + \frac{32}{100} = \frac{72}{100}$

Equation 3:  $\frac{7}{10} + \frac{2}{100} = \frac{27}{100}$

Equation 4:  $\frac{6}{10} + \frac{27}{100} = \frac{87}{100}$

Which equation or equations are true?

- A equation 1 only
- B equation 2 only
- C equations 3 and 4 only
- D equations 2 and 4 only

7. What is the product of  $\frac{5}{8} \times \frac{3}{4}$ ?

**A**  $\frac{8}{32}$

**B**  $\frac{15}{32}$

**C**  $\frac{8}{12}$

**D**  $\frac{15}{12}$

8. What is the value of the expression below?

$$\frac{1}{4} \div 8$$

**A**  $\frac{1}{32}$

**B**  $\frac{1}{2}$

**C** 2

**D** 32

9. In a shipment of new books for a library,  $\frac{5}{12}$  of the books were poetry and  $\frac{2}{5}$  were biographies. The remainder of the books in the shipment were mysteries. What fraction of the books in the shipment were mysteries?

A  $\frac{2}{12}$

B  $\frac{11}{60}$

C  $\frac{7}{17}$

D  $\frac{49}{60}$

10. What is the value of the expression below?

$$\begin{array}{r} 3\frac{1}{4} \\ -1\frac{7}{8} \\ \hline \end{array}$$

A  $1\frac{1}{4}$

B  $1\frac{3}{8}$

C  $2\frac{3}{8}$

D  $3\frac{1}{2}$



11. The sign below is located at the start of Pinecone Trail and shows the distances from the sign to different points of interest along the trail.

| Pinecone Trail |                      |
|----------------|----------------------|
| Nature Center  | $1\frac{1}{2}$ miles |
| Giant Boulder  | $4\frac{1}{4}$ miles |
| Lookout Point  | $8\frac{3}{4}$ miles |

Sage hiked from the start of the trail to Lookout Point. She then hiked back to Giant Boulder to camp for the night. What was the total distance, in miles, that Sage hiked?

- A  $21\frac{3}{4}$
- B  $13\frac{1}{4}$
- C  $4\frac{1}{2}$
- D  $4\frac{1}{4}$
12. What is the value of the expression below?

$$56 \div \frac{1}{17}$$

- A  $\frac{1}{952}$
- B  $\frac{17}{56}$
- C  $3\frac{5}{17}$
- D 952

13. Kim's class voted on a location for a field trip.

- $\frac{3}{4}$  of the class voted for the museum
- $\frac{1}{8}$  of the class voted for the zoo

The rest of the class voted for the nature park.

What fraction of the class voted for the nature park?

- A  $\frac{1}{8}$
- B  $\frac{1}{2}$
- C  $\frac{5}{8}$
- D  $\frac{7}{8}$

14. Tara baked  $6\frac{1}{2}$  dozen cookies. She sold  $3\frac{2}{6}$  dozen of the cookies she made.  
How many dozens of cookies does Tara have remaining?

- A  $3\frac{1}{6}$
- B  $3\frac{1}{4}$
- C  $3\frac{3}{8}$
- D  $3\frac{5}{6}$

15. What is the value of the expression  $\frac{1}{5} \div 4$ ?

A  $\frac{20}{1}$

B  $\frac{5}{4}$

C  $\frac{4}{5}$

D  $\frac{1}{20}$

16. Which expression is equivalent to  $\frac{3}{5}$ ?

A  $3 \times 5$

B  $3 + 5$

C  $3 \div 5$

D  $3 - 5$

17. For which values of  $k$  would the product of  $\frac{k}{3} \times 12$  be greater than 12?

- A for any value of  $k$  less than 1 but greater than 0
- B for any value of  $k$  less than 3 but greater than 1
- C for any value of  $k$  equal to 3
- D for any value of  $k$  greater than 3

18. Dawn hiked  $\frac{1}{2}$  mile over rough terrain this morning. The point she is hiking towards is  $\frac{7}{8}$  mile from where she started this morning. How much farther must Dawn hike to reach her goal?

- A.  $\frac{1}{8}$  mile
- B.  $\frac{3}{8}$  mile
- C.  $\frac{1}{4}$  mile
- D.  $1\frac{1}{8}$  mile

19. Mr. Johnson brought  $\frac{2}{3}$  of a tray of rice pudding to a pot luck dinner. The group at the dinner ate  $\frac{3}{4}$  of what Mr. Johnson brought. How much of the original tray of rice pudding was eaten at the pot luck dinner?

A.  $\frac{3}{4}$

B.  $\frac{1}{2}$

C.  $\frac{1}{3}$

D.  $\frac{1}{4}$

20. A snail traveled  $\frac{1}{4}$  foot in 10 minutes. At this rate, how far does the snail travel in 1 minute?

A.  $\frac{1}{40}$  foot

B.  $\frac{1}{14}$  foot

C.  $\frac{2}{5}$  foot

D.  $2\frac{1}{2}$  foot

## Problem Set

What is the value of the expression below?

$$\frac{1}{25} \div 74$$

- A  $\frac{1}{1,850}$
- B 1,850
- C  $\frac{25}{74}$
- D  $2\frac{24}{25}$

## Application Problem

Elma has \$45. She gives  $\frac{2}{5}$  of her money to her sister. How much money did she give her sister?

- A \$3.50
- B \$7.00
- C \$14.00
- D \$18.00

## Exit Ticket

The students in a fifth-grade class had a choice of white milk, chocolate milk, or lemonade for lunch.

$\frac{4}{9}$  chose white milk

$\frac{1}{3}$  chose chocolate milk

The rest chose lemonade

What fraction of the students chose lemonade?

A.  $\frac{1}{9}$

B.  $\frac{2}{9}$

C.  $\frac{2}{3}$

D.  $\frac{7}{9}$



**Brighter Choice**  
Charter School for Boys

# Day # 5

**NYS Math Review – Packet 4**

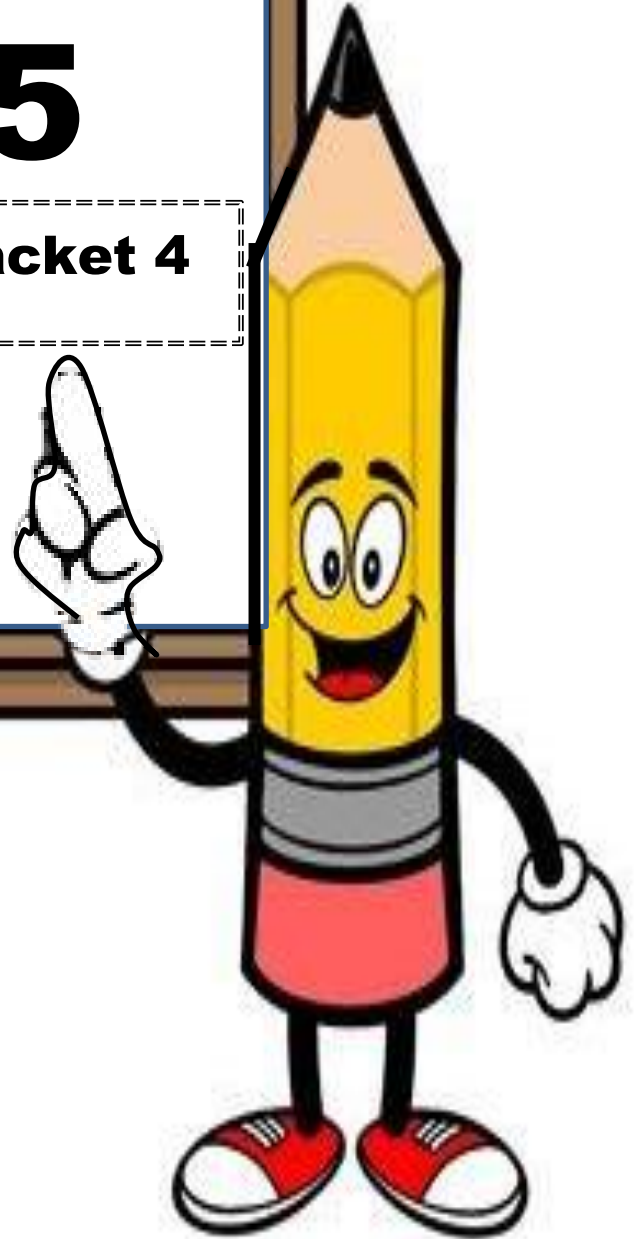



Name: \_\_\_\_\_ Week 32 Day 5 Date: \_\_\_\_\_

BCCS-Boys

Stanford MIT

**Do Now**

What is the expression of the value below?

$$4\frac{1}{4} - 3\frac{1}{3}$$

A.  $\frac{11}{12}$

B.  $\frac{5}{6}$

C.  $1\frac{1}{3}$

D.  $1\frac{1}{12}$

**NYS Math Review Packet 4:**  
**Fractions and Line Plots Review**

**1.** Shawna rode her bike  $\frac{5}{6}$  of a mile. Debbie rode her bike  $\frac{1}{3}$  of a mile.  
How much farther did Shawna ride than Debbie?

- A**  $\frac{1}{4}$  of a mile
- B**  $\frac{1}{2}$  of a mile
- C**  $\frac{2}{3}$  of a mile
- D**  $1\frac{1}{6}$  miles

**2.** Miranda's class recorded the snowfall during January and created this line plot.

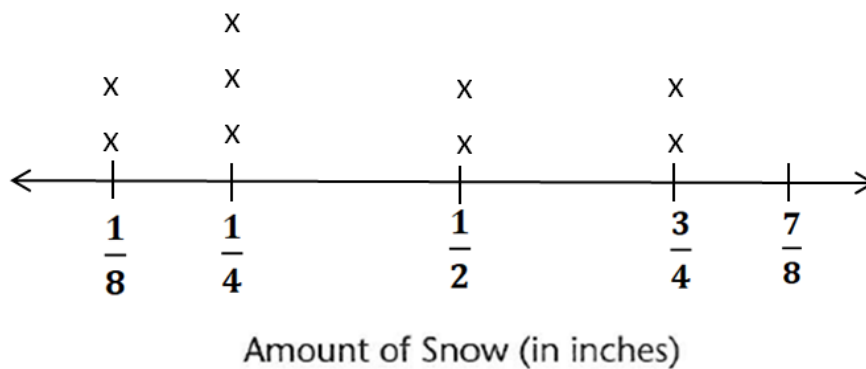

How many inches of snow fell, in total, on days that received  $\frac{1}{2}$  inch or more?

- A** 2
- B**  $2\frac{1}{4}$
- C**  $2\frac{1}{2}$
- D**  $2\frac{3}{4}$

3. Harry is making dessert for his family. Each serving requires  $\frac{1}{5}$  of a tablespoon of vanilla. Harry needs to make 6 servings. How many tablespoons of vanilla does he need?

- A  $\frac{1}{5}$   
B  $\frac{1}{30}$   
C  $1\frac{1}{6}$   
D  $1\frac{1}{5}$

4. The sign below is located at the entrance of a national park. It shows the distances of three popular biking trails.

|                     |                      |
|---------------------|----------------------|
| Parkway Trail:      | $8\frac{1}{4}$ miles |
| Snake Creek Trail:  | $6\frac{5}{6}$ miles |
| Lehigh River Trail: | $4\frac{3}{4}$ miles |

Kirk wants to ride his bike on both the Parkway Trail and the Lehigh River Trail. How many miles will he ride in all?

- A 12  
B  $15\frac{1}{3}$   
C 13  
D  $16\frac{1}{4}$

5. On Monday, Harriet ate  $\frac{1}{4}$  of an 8-slice pizza. On Tuesday, she ate  $\frac{1}{2}$  of the same pizza. What fraction of the whole pizza did she eat?

A  $\frac{3}{4}$

B  $\frac{5}{8}$

C  $\frac{2}{6}$

D  $\frac{1}{6}$

6. What is the value of the expression below?

$$\begin{array}{r} 3\frac{2}{3} \\ - 1\frac{5}{6} \\ \hline \end{array}$$

A  $1\frac{1}{3}$

B  $1\frac{5}{6}$

C  $2\frac{1}{6}$

D  $2\frac{1}{2}$

- 7.** Jamie spends \$32 on four pairs of socks. Three pairs of socks are black and one pair is brown. Which expression represents the total cost of the brown socks?

A.  $32 \times \frac{4}{1}$

B.  $32 \times \frac{1}{4}$

C.  $\frac{32}{4} \times \frac{1}{3}$

D.  $\frac{32}{3} \times \frac{1}{4}$

- 8.** Mark used  $\frac{1}{3}$  cup of a sugar to make muffins and  $\frac{2}{3}$  cup of sugar to make a cake. How much sugar did Mark use in all?

A  $\frac{2}{9}$  cup

B  $\frac{3}{6}$  cup

C 1 cup

D  $1\frac{1}{3}$  cup

9. Rita cut a piece of string into several small pieces for an art project. The line plot below shows the lengths of the pieces.

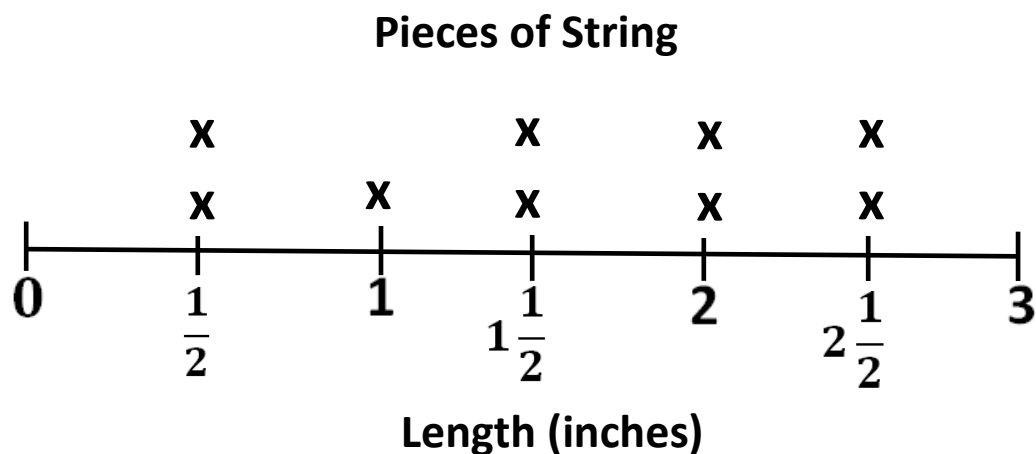

What is the total length, in inches, of the five shortest pieces of string?

- A  $4\frac{1}{2}$
- B 5
- C 6
- D 7

**10.** Guests at a wedding had a choice of three main courses: fish, beef or chicken.

$\frac{2}{5}$  of the guests ordered fish

$\frac{3}{10}$  of the guests ordered beef

The rest of the guests ordered chicken

What fraction of the guests ordered chicken?

A.  $\frac{1}{5}$

B.  $\frac{3}{10}$

C.  $\frac{7}{10}$

D.  $\frac{11}{10}$

**11.** It rained for  $\frac{2}{3}$  of the 21 days Jerry spent on vacation last summer. On how many days did it rain during Jerry's vacation?

A. 14

B. 15

C. 18

D. 20

**12.** The Cedar Glen Trail is  $2\frac{7}{8}$  miles long and the Rocky Falls Trail is  $1\frac{1}{2}$  miles long. How much longer is the Cedar Glen Trail than the Rocky Falls Trail?

A.  $1\frac{3}{4}$  miles

B.  $1\frac{3}{8}$  miles

C.  $3\frac{8}{10}$  miles

D.  $4\frac{3}{8}$  miles



**13.** Henry has 6 pounds of meat to make hamburgers. He uses  $\frac{1}{4}$  pound of meat for each hamburger. How many hamburgers can Henry make?

A. 1.5

B. 10

C. 16

D. 24

**14.** Which values of  $a$  and  $b$  will make the equation true?

$$6 \times \frac{a}{b} = 6$$

A.  $a = 6$ ,  $b = 6$

B.  $a = 10$ ,  $b = 6$

C.  $a = 6$ ,  $b = 1$

D.  $a = 20$ ,  $b = 10$

15. Which rule describes the relationship between  $a$  and  $b$  in the table below?

| $A$           | $b$            |
|---------------|----------------|
| $\frac{1}{4}$ | $\frac{3}{4}$  |
| 1             | $1\frac{1}{2}$ |

A.  $a + \frac{1}{2} = b$

B.  $a + \frac{1}{4} = b$

C.  $a - \frac{1}{4} = b$

D.  $a - \frac{1}{2} = b$

16. Richard recorded how far he walked after school each day for 12 days. He displayed his data in the line plot below.

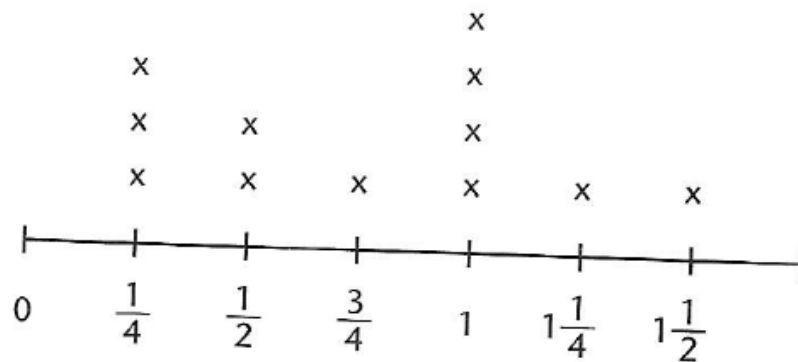

What was the total number of miles for days on which Richard walked  $1\frac{1}{4}$  mile or more?

A.  $2\frac{3}{4}$

B. 4

C.  $6\frac{1}{2}$

D. 6

**17.** Zelda bought ribbon for an art project. The lengths and colors of the ribbons are shown below.

- $\frac{1}{2}$  meter of blue ribbon
- $3\frac{3}{4}$  meters of pink ribbon
- $2\frac{3}{4}$  meters of yellow ribbon

How much ribbon does Zelda have in all?

How much ribbon does Zelda have in all?

A.  $6\frac{1}{2}$

B.  $6\frac{3}{4}$

C. 7

D.  $7\frac{1}{2}$

**18.** For a recipe Will needs  $\frac{3}{5}$  cups of flour per serving. Will needs to make enough for 4 people. How many cups of flour does he need?

A.  $1\frac{4}{5}$

B.  $4\frac{2}{5}$

C.  $2\frac{2}{5}$

D.  $3\frac{2}{5}$

**19.** The line plot shows the weights of ten eggs laid by one hen.

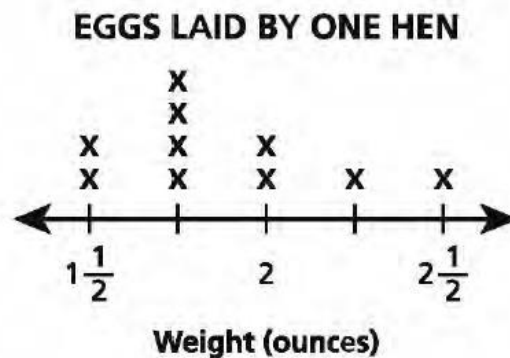

What is the total weight, in ounces, of the four heaviest eggs?

A 4

B 7

C  $8\frac{1}{2}$

D  $8\frac{3}{4}$

## Problem Set

Marcia has  $\frac{3}{4}$  of a pizza. She wants to give  $\frac{1}{2}$  of the pizza to a friend. What fraction of the pizza will be left?

- A  $\frac{1}{4}$
- B  $\frac{1}{3}$
- C  $1\frac{1}{4}$
- D  $1\frac{1}{2}$

## Application Problem

A pitcher contains  $4\frac{1}{2}$  pints of lemonade. Harley pours  $1\frac{5}{8}$  of a pint into a glass, and Mateo pours  $\frac{1}{2}$  pint into a glass.

How much lemonade is left in the pitcher?

- A.  $\frac{1}{8}$  of a pint
- B.  $\frac{9}{8}$  of a pint
- C.  $2\frac{2}{8}$  pints
- D.  $2\frac{3}{8}$  pints

## Exit Ticket

Maria is working in the school library.

- $\frac{1}{2}$  of the books are nonfiction
- $\frac{3}{8}$  of the books are fiction
- The rest of the books are textbooks.

What fraction of the books are textbooks?

A.  $\frac{1}{8}$

B.  $\frac{7}{8}$

C.  $\frac{1}{4}$

D.  $\frac{1}{2}$



Name \_\_\_\_\_

# 5<sup>th</sup> Grade Math Remote Learning Packet

## Week 33



Dear Educator,

My signature is proof that I have reviewed my scholar's work and supported him to the best of my ability to complete all assignments.

\_\_\_\_\_  
(Parent Signature)

\_\_\_\_\_  
(Date)

Parents please note that all academic packets are also available on our website at [www.brighterchoice.org](http://www.brighterchoice.org) under the heading "Remote Learning." All academic packet assignments are mandatory and must be completed by all scholars.



# Day # 1

**NYS Math Review – Packet 4**

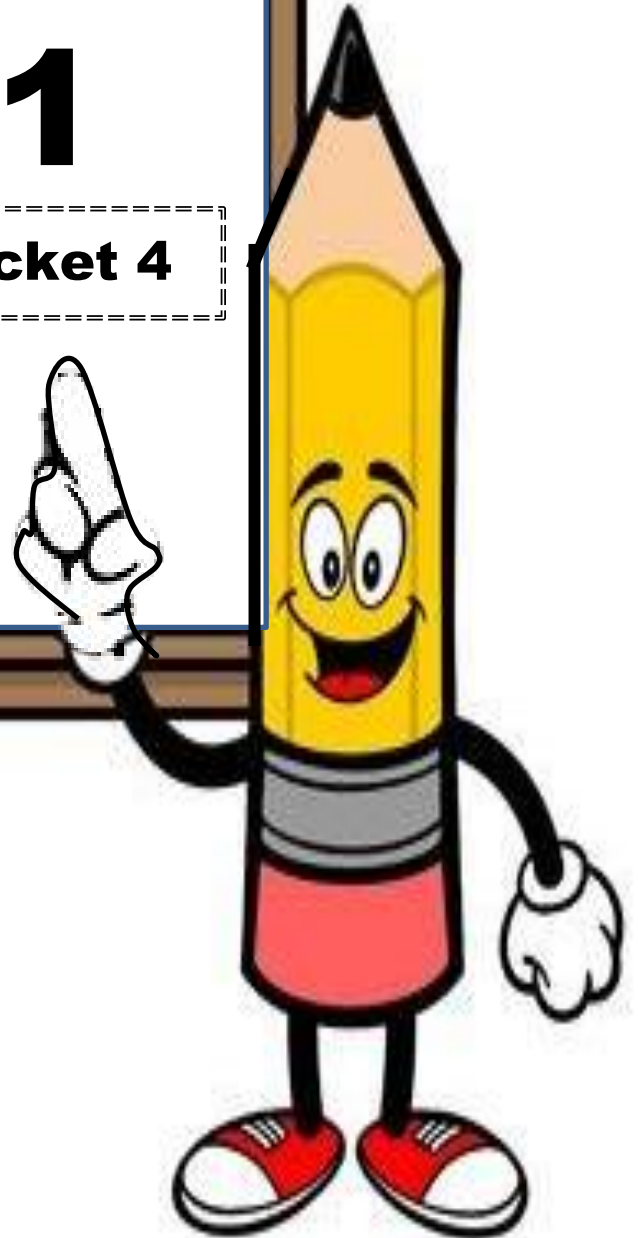



Name: \_\_\_\_\_ Week 33 Day 1 Date: \_\_\_\_\_

BCCS-Boys

Stanford MIT

**Do Now**

What is the volume, in cubic centimeters, of the figure below?

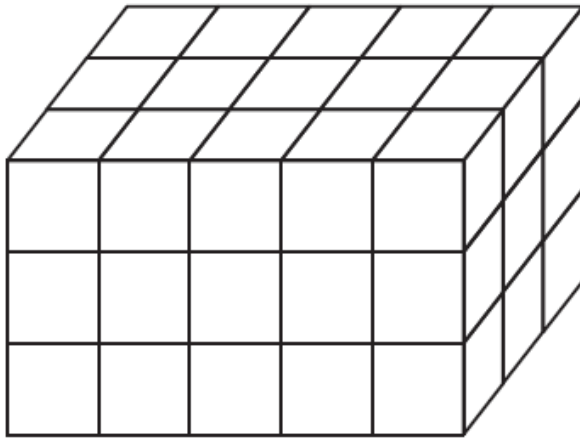

= 1 cubic centimeter

- A** 15
- B** 24
- C** 30
- D** 45

**NYS Math Review Packet 5:**  
**Volume, Area and Quadrilaterals Review**

1. Which diagram represents a volume of one cubic unit?

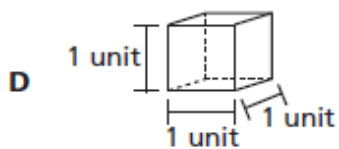
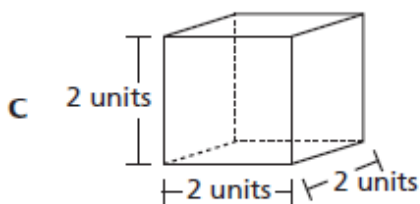
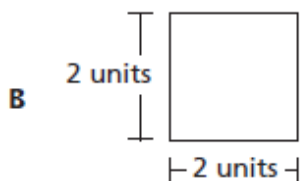
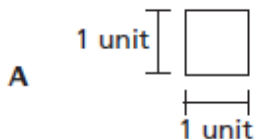

2. Which phrase describes the volume of a 3-dimensional figure?

- A the number of square units it takes to fill a solid figure
- B the number of cubic units it takes to fill a solid figure
- C the number of square units it takes to cover the outside of a solid figure
- D the number of cubic units it takes to cover the outside of a solid figure

3. Jim gave the following description of a figure:

- It is a quadrilateral.
- All sides are equal in length.
- There are two equal obtuse angles and two equal acute angles.

Which figure **could** match Jim's description?

- A** rectangle
- B** rhombus
- C** square
- D** pentagon

4. Which phrase best describes a figure with dimensions of 2 units by 2 units by 4 units and a volume of 16 cubic units?

- A** a solid figure that can be filled with 16 cubes that each measure 1 cubic unit
- B** a solid figure that can be filled with 1 cube that measures 16 units on each edge
- C** a solid figure that can be covered with 16 squares that each measure 1 square unit
- D** a solid figure that can be covered with 1 square that measures 16 units on each edge

5. Rashad is filling a toy box with wooden blocks that are each a unit cube in size. He filled the bottom layer of a toy box with 15 wooden blocks. He then stacked two more wooden blocks on top of the bottom layer. The partially filled toy box is shown below.

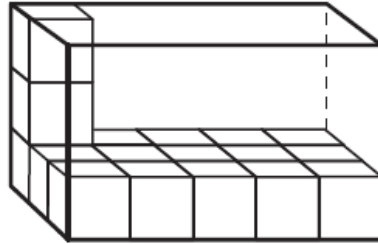

What was the total volume, in cubic units, of the toy box?

- A 15  
B 17  
C 30  
D 45
6. What is the area, in square inches, of a rectangle with the dimensions shown in the diagram below?

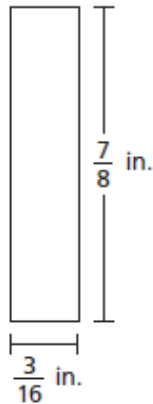

- A  $\frac{21}{128}$   
B  $\frac{3}{14}$   
C  $\frac{10}{24}$   
D  $\frac{24}{112}$

7. Jack used cubes to make the right rectangular prism below.

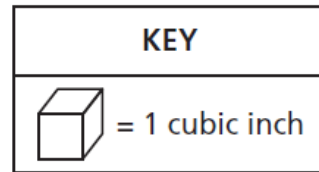
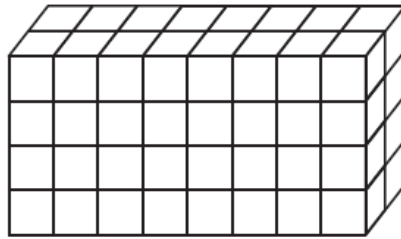

He then made a smaller right rectangular prism using  $\frac{1}{4}$  of the number of cubes. What was the volume, in cubic inches, of the smaller right rectangular prism?

- A 8
  - B 13
  - C 16
  - D 64
8. Which of these is a rectangle?

- A. pentagon
- B. trapezoid
- C. square
- D. rhombus

9. Tyler completely filled the box shown below with unit cubes, with no gaps or overlaps.

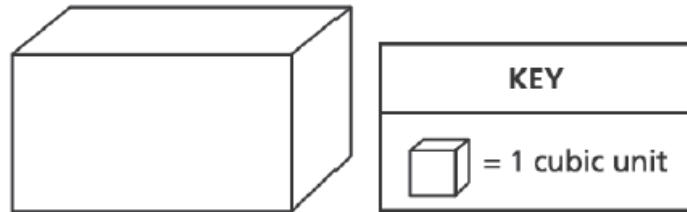

He then counted the number of cubes that he used to fill the box. What type of measurement is represented by the number of cubes Tyler counted?

- A area
  - B height
  - C volume
  - D perimeter
10. Which type of quadrilateral can have exactly 1 pair of parallel sides?
- A rectangle
  - B rhombus
  - C square
  - D trapezoid

11. Prism X is shown below. The volume of Prism Y is 10 cubic centimeters greater than the volume of Prism X.

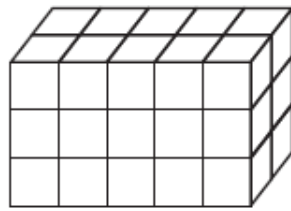

Prism X

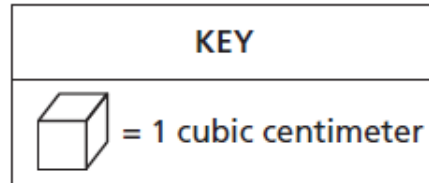

What is the volume of Prism Y?

- A. 30 cubic centimeters
  - B. 40 cubic centimeters
  - C. 10 cubic centimeters
  - D. 20 cubic centimeters
12. Parallelograms **always** belong to which category of shapes?
- A squares
  - B rectangles
  - C rhombuses
  - D quadrilaterals

13. Which model shows one way to determine the area of a rectangle that is  $\frac{7}{10}$  meter long and  $\frac{3}{5}$  meter wide?

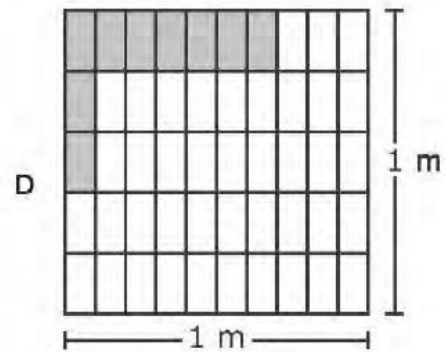
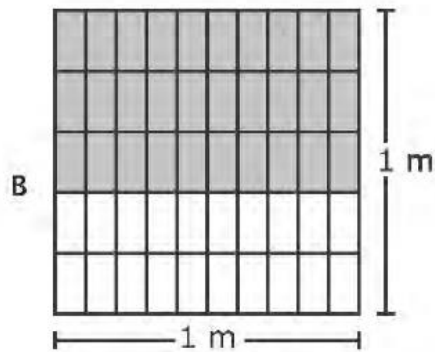
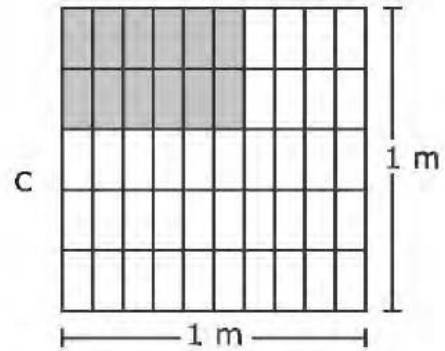
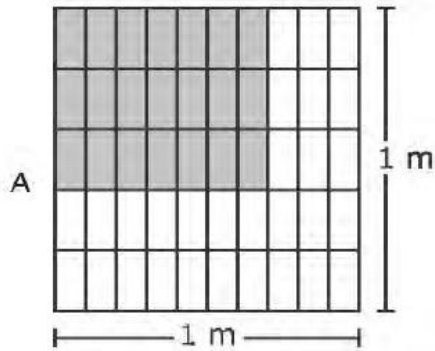

14. Which type of quadrilateral always has four right angles?

- A. kite
- B. trapezoid
- C. rhombus
- D. rectangle



15. In her math class, Carla used unit cubes to build a right rectangular prism with a volume of 24 cubic units. The height of the prism was two units. Which figure could be the bottom layer of the prism?

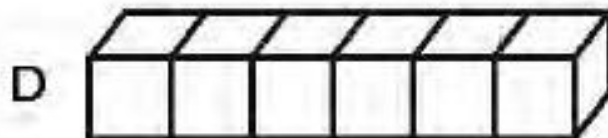
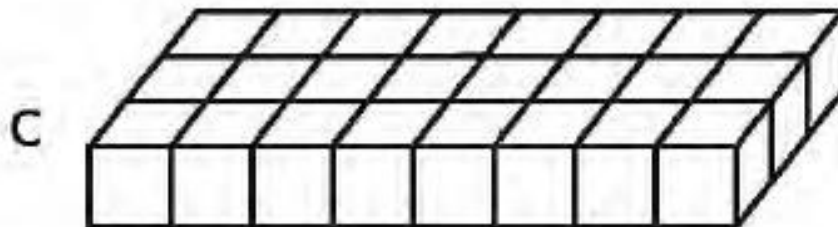
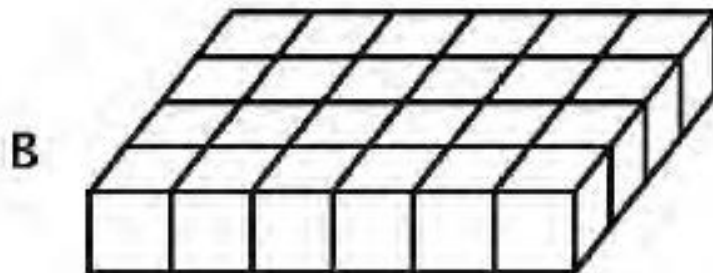
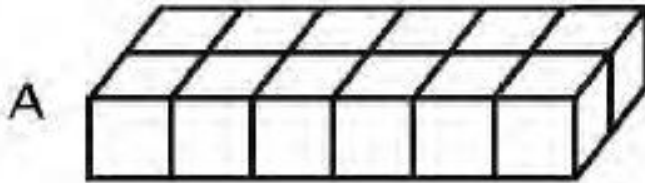

## Problem Set

The table below lists the number of layers of centimeter cubes, along with the number of cubes in each layer, in each of four rectangular prisms.

**LAYERS OF CUBES IN RECTANGULAR PRISMS**

| Prism | Number of Layers | Number of Cubes in Each Layer |
|-------|------------------|-------------------------------|
| R     | 3                | 8                             |
| S     | 5                | 5                             |
| T     | 6                | 5                             |
| U     | 7                | 4                             |

Which rectangular prism has the greatest volume?

- A Prism R
- B Prism S
- C Prism T
- D Prism U

## Application Problem

A swimming pool is shaped like a right rectangular prism. The pool is 36 feet long and 20 feet wide. What is the total amount of water, in cubic feet, needed to fill the pool to a depth of 4 feet? Parallelogram

- A. 800
- B. 864
- C. 2,880
- D. 5,760

## Exit Ticket

The figure below is made of unit cubes.

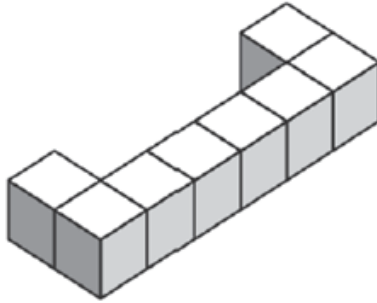

How many unit cubes need to be added to the figure so that it will have a total volume of 12 cubic units?

A.1

B.2

C.4

D.8



Brighter Choice  
Charter School for Boys

# Day # 2

**NYS Math Review – Packet 6**

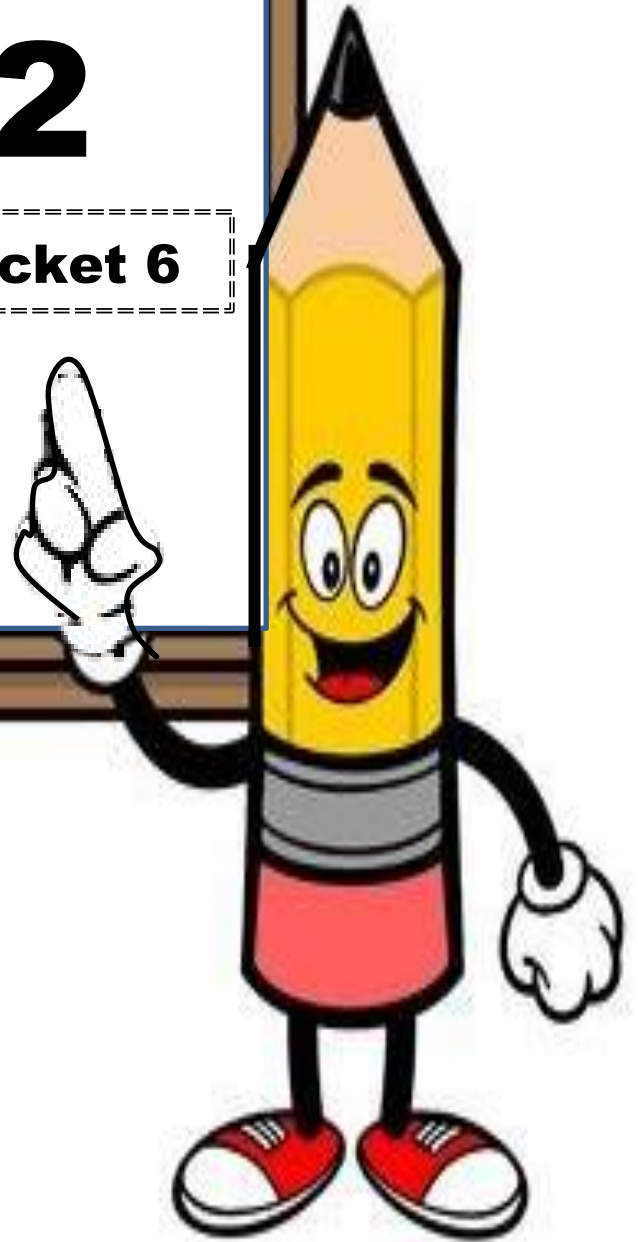

Name: \_\_\_\_\_ Week 33 Day 2 Date: \_\_\_\_\_

BCCS-Boys

Stanford MIT

**Do Now**

Solve the following questions.

Which shape always has 4 congruent sides?

- A. parallelogram
- B. rectangle
- C. rhombus
- D. trapezoid

Lyric drew in which all the angles were obtuse. What kind of polygon could he have drawn?

- A. trapezoid
- B. parallelogram
- C. triangle
- D. pentagon

**NYS Math Review Packet 6:**  
**Volume, Area and Quadrilaterals Review**

1. A toy company uses the box shown below to package wooden cubes.

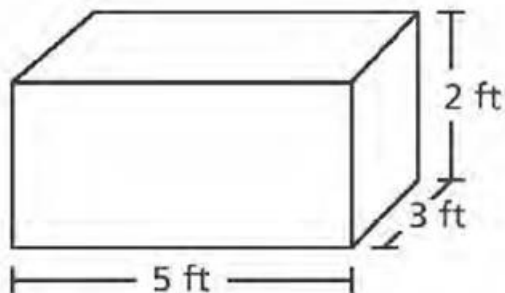

What is the volume of the box?

- A.  $20 \text{ ft}^3$
  - B.  $15 \text{ ft}^3$
  - C.  $30 \text{ ft}^3$
  - D.  $45 \text{ ft}^3$
2. A square and a rhombus are shown below.



Which attribute is true of one of the shapes but **not** of both?

- A All angles are right angles.
- B All sides are the same length.
- C There are two sets of equal angles.
- D There are two sets of parallel sides.

3. A right rectangular prism is shown below. The volume of the prism is determined by using unit cubes.

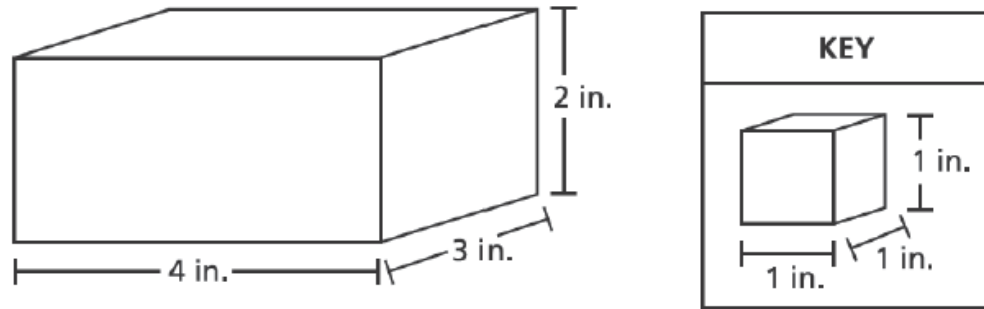

Which statement describes how to determine the volume of the prism in cubic units?

- A Add the length, width, and height:  $4 + 3 + 2$ .
  - B Add the length and width and then multiply by the height:  $(4 + 3) \times 2$ .
  - C Determine the area of the base and add the number of layers of cubes:  $(4 \times 3) + 2$ .
  - D Determine the area of the base and multiply by the number of layers of cubes:  $(4 \times 3) \times 2$ .
4. What is the volume of the cube shown below?

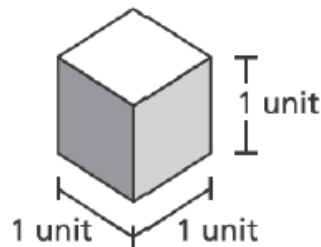

- A 1 cubic unit
- B 3 cubic units
- C 4 cubic units
- D 6 cubic units

5. The dimensions of Mr. Tai's living room are 10 feet  $\times$  18 feet  $\times$  8 feet, and the dimensions of his family room are 14 feet  $\times$  20 feet  $\times$  8 feet. What is the total volume, in cubic feet, of the two rooms?

A. 1,440 ft<sup>3</sup>

B. 2,240 ft<sup>3</sup>

C. 3,880 ft<sup>3</sup>

D. 3,680 ft<sup>3</sup>

6. Maria drew a rectangle. Which categories could her rectangle fit?



A. hexagon

B. quadrilateral

C. trapezoid

D. triangle



7. A right rectangular prism is 11 inches long, 7 inches wide, and 4 inches high. What is the volume of the rectangular prism in cubic inches?

A. 24

B. 96

C. 308

D. 384

8. Which statement is true?

**A** All parallelograms are rectangles.

**B** All rectangles are squares.

**C** All quadrilaterals are rectangles.

**D** All squares are rhombuses.

9. What is the area of the square shown below?

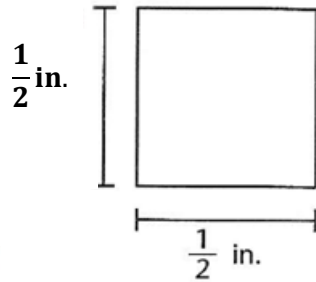

- A.  $\frac{1}{8}$  square inch
- B.  $\frac{1}{4}$  square inch
- C.  $\frac{1}{2}$  square inch
- D. 1 square inch
10. Barry drew a quadrilateral with no right angles. One pair of opposite sides in this quadrilateral was parallel and measured 5 centimeters. The other pair of opposite sides was parallel and measured 3 centimeters. What type of figure did Barry draw?
- A. rhombus
- B. parallelogram
- C. rectangle
- D. trapezoid

11. Which of these is a rectangle?

- A. pentagon
- B. trapezoid
- C. square
- D. rhombus

12. The figure below is made from unit cubes. Each cube has edges of length 1 centimeter. What is the volume of the figure?

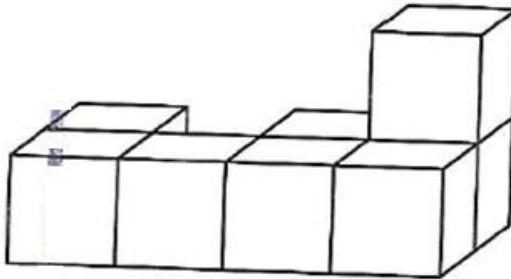

- A. 6 cubic centimeters
- B. 7 cubic centimeters
- C. 8 cubic centimeters
- D. 9 cubic centimeters

13. Which figure can be filled with unit cubes to measure its volume?

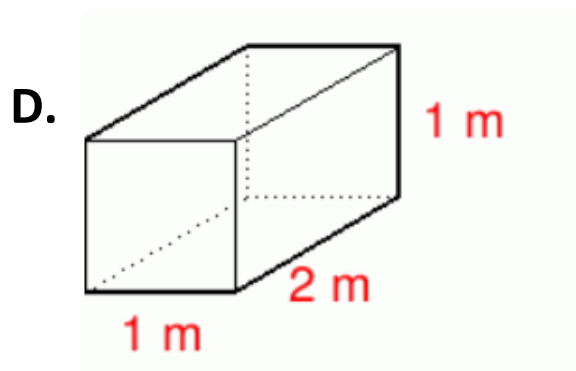
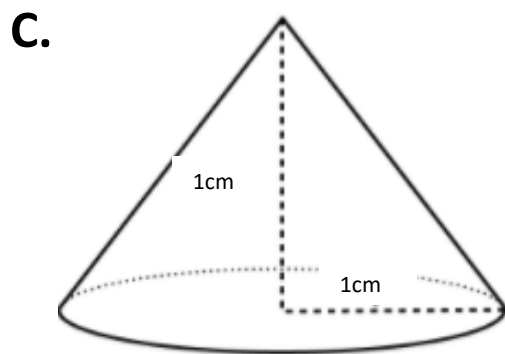
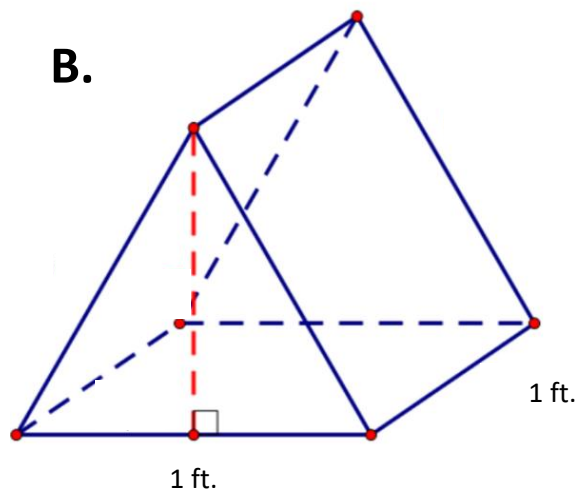
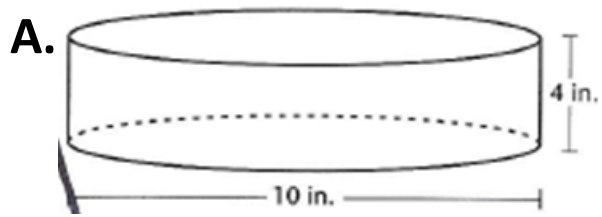

14. Find the volume.

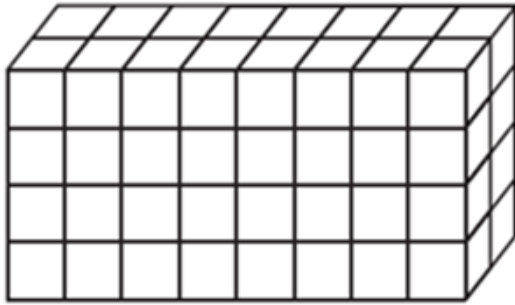

A. 14

B. 32

C. 64

D. 96

15. Patrick has a box whose length is 12 cm, height 8 cm, and width 6 cm. Find the volume of the box.

A.  $540 \text{ cm}^3$

B.  $567 \text{ cm}^3$

C.  $576 \text{ cm}^3$

D.  $26 \text{ cm}^3$

## Problem Set

What is the volume of the following rectangular prism?

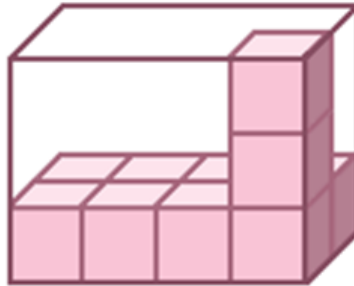

- A. 24
- B. 12
- C. 22
- D. 20

## Application Problem

What is the area of the following shape?

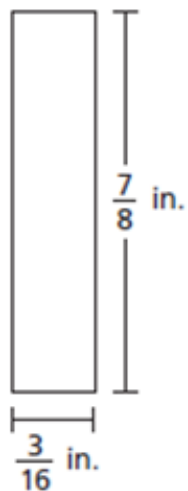

## Exit Ticket

Jack used cubes to make the right rectangular prism below.

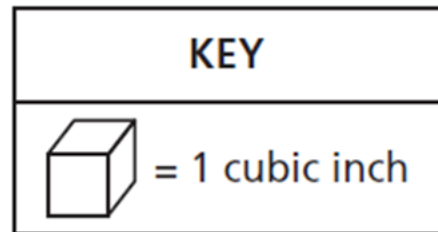
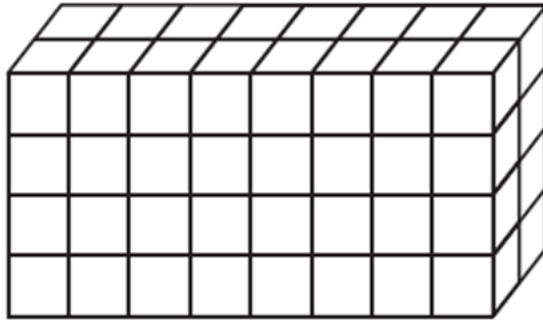

He then made a smaller right rectangular prism using  $\frac{1}{4}$  of the number of cubes. What was the volume, in cubic inches, of the smaller right rectangular prism?

- A. 8
- B. 13
- C. 16
- D. 64



Brighter Choice  
Charter School for Boys

# Day # 3

## NYS Math Test

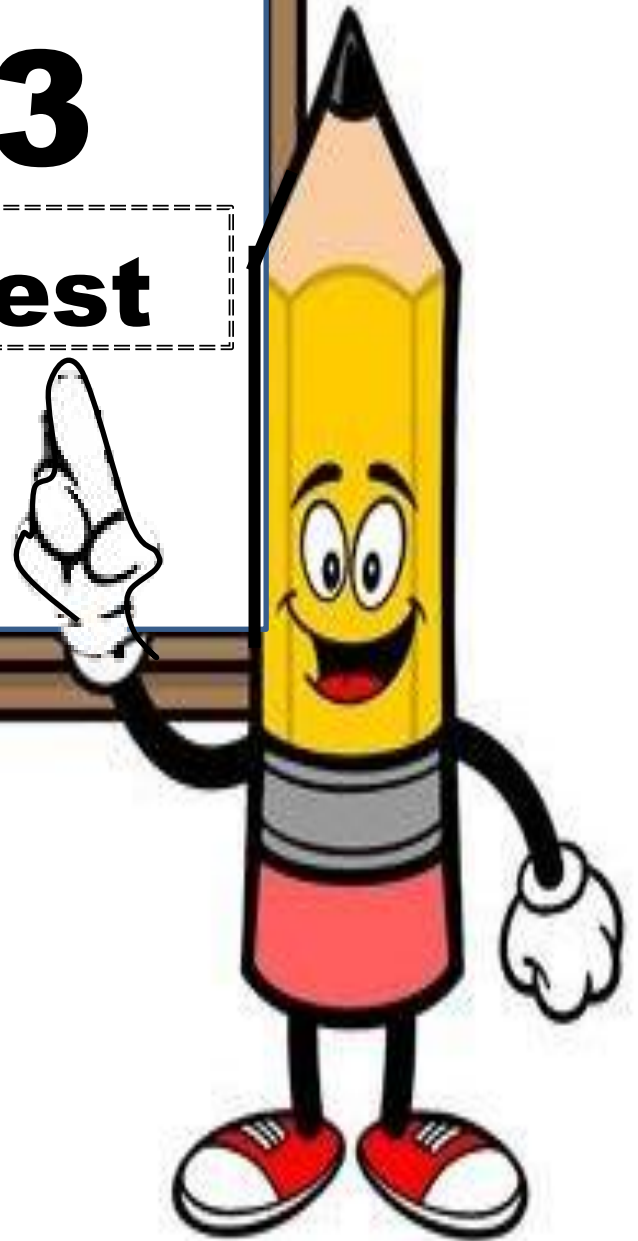





# Day # 4

**Mod 6 Packet 1**

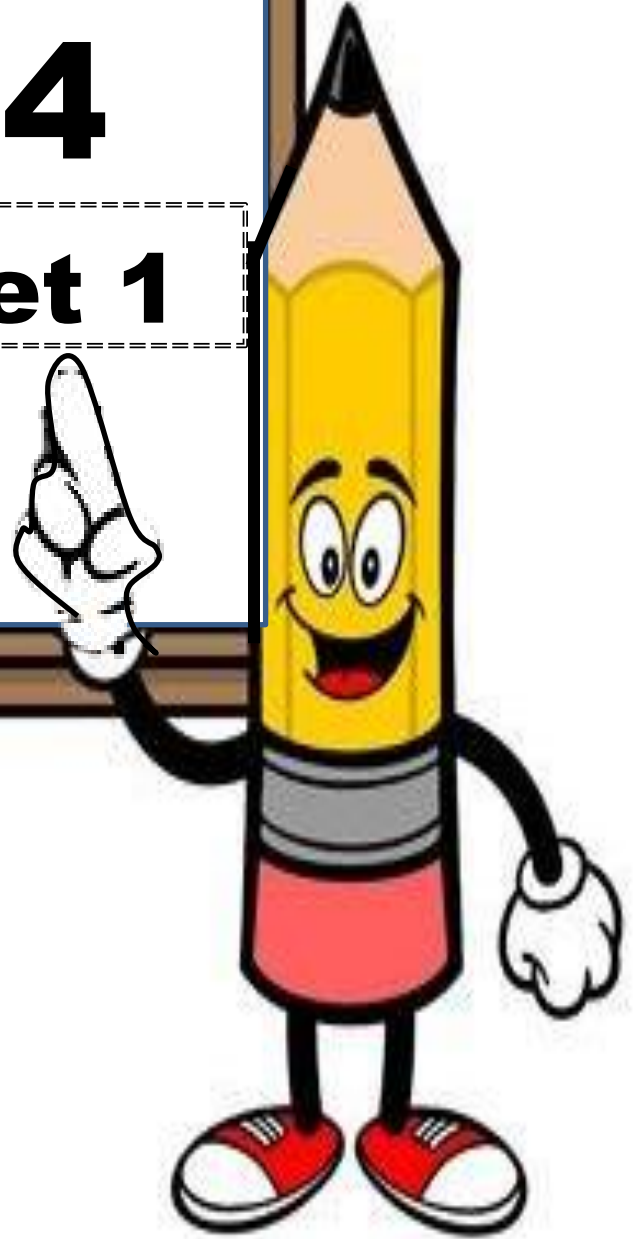

Name: \_\_\_\_\_ Week 33 Day 4 Date: \_\_\_\_\_

BCCS-Boys

Stanford MIT

### Do Now

Find each volume.

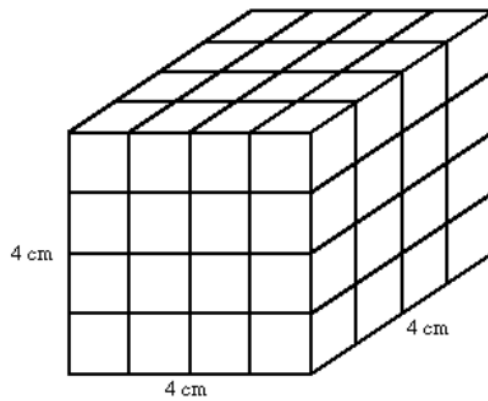

**V =** \_\_\_\_\_

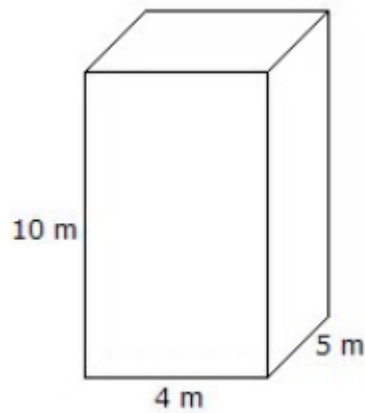

**V =** \_\_\_\_\_

## Input Activity

### Key Terms:

Origin – the \_\_\_\_\_ point (\_\_\_\_\_, \_\_\_\_\_)

Coordinate – a \_\_\_\_\_ of \_\_\_\_\_ that describe the \_\_\_\_\_ of a point on a coordinate \_\_\_\_\_

Vertical Number Line – a \_\_\_\_\_ line that goes \_\_\_\_\_ and \_\_\_\_\_

Horizontal Number Line – a \_\_\_\_\_ line that goes \_\_\_\_\_ to \_\_\_\_\_

### Problem 1

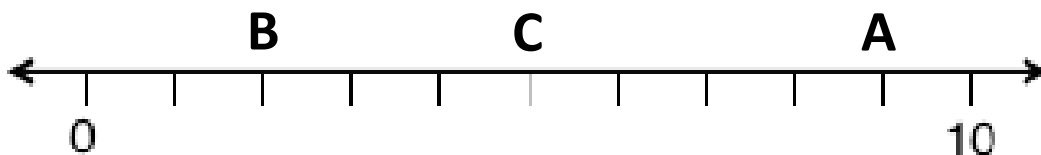

What is the coordinate for A? \_\_\_\_\_

What is the coordinate for B? \_\_\_\_\_

What is the coordinate for C? \_\_\_\_\_

### Problem 2

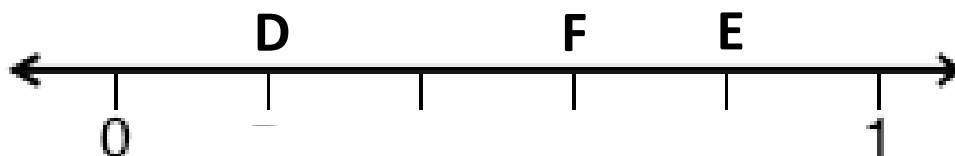

What is the coordinate for D? \_\_\_\_\_

What is the coordinate for E? \_\_\_\_\_

What is the coordinate for F? \_\_\_\_\_

### Problem 3

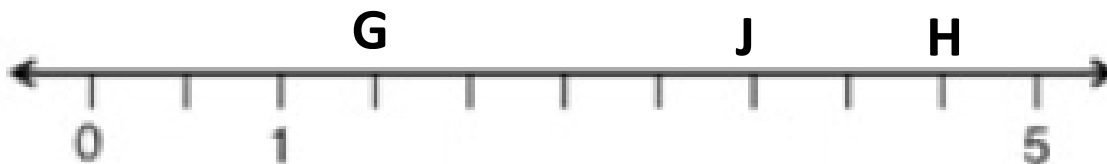



What is the coordinate for G? \_\_\_\_\_

What is the coordinate for H? \_\_\_\_\_

What is the coordinate for J? \_\_\_\_\_

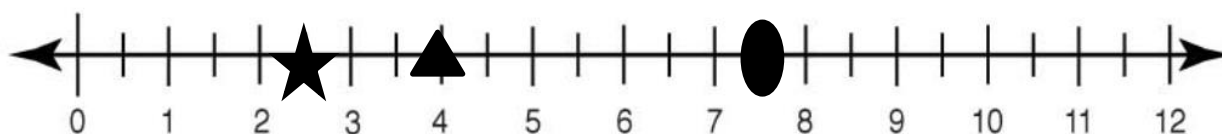
### Problem 4:



What is the star's coordinate ? \_\_\_\_\_

What is the triangle's coordinate ? \_\_\_\_\_

What is the circle's coordinate ? \_\_\_\_\_

### Problem 5:

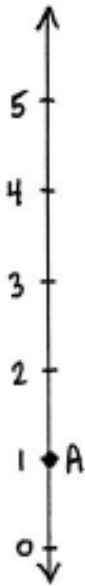

What is A's coordinate? \_\_\_\_\_

So A's distance from the origin is \_\_\_\_\_

### Problem 6:

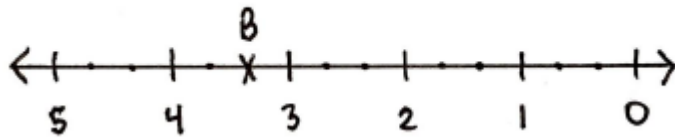

What is B's coordinate? \_\_\_\_\_

So B's distance from the origin is \_\_\_\_\_

**Problem 7:**

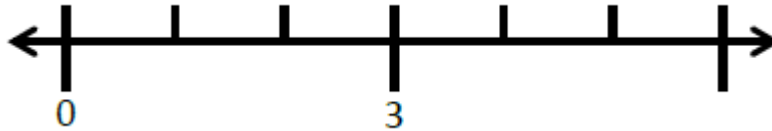

Plot **A** so that its distance from the origin is **2**.

**Problem 8:**

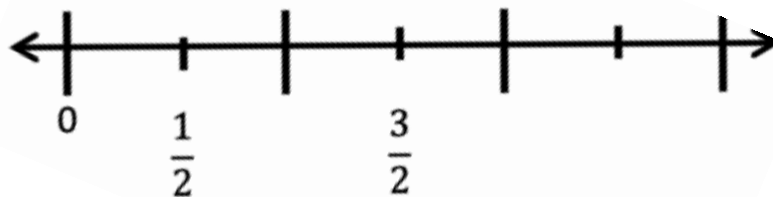

Plot **R** so that its distance from the origin is  $\frac{5}{2}$ .

**Problem 9:**

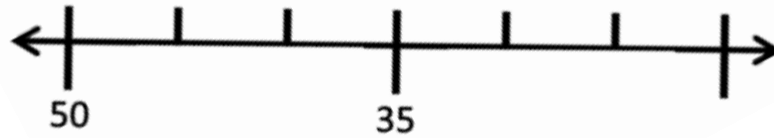

Plot L so that its distance from the origin is **20**.

**Problem 10:**

Plot T so that its distance from the origin is  $\frac{2}{3}$  more than **S**





### Problem 11:

Number line  $g$  is labeled from 0 to 6. Use number line  $g$  below to answer the questions.

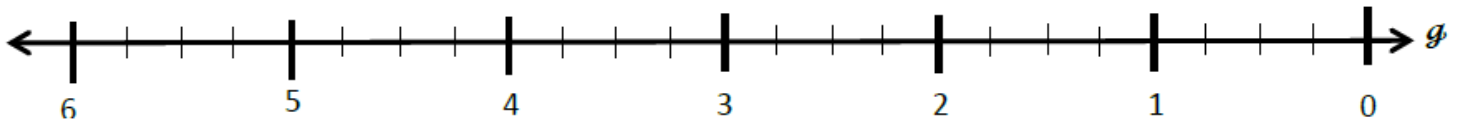

- Plot point  $A$  at  $\frac{3}{4}$
- Label a point that lies at  $4\frac{1}{2}$  as  $B$ .
- Label a point,  $C$ , whose distance from zero is 5 more than that of  $A$ . The coordinate of  $C$  is \_\_\_\_\_
- Plot a point,  $D$ , whose distance from zero is  $1\frac{1}{4}$  less than that of  $B$ .  
The coordinate of  $D$  is \_\_\_\_\_
- The distance of  $E$  from zero is  $1\frac{3}{4}$  more than that of  $D$ . Plot point  $E$ .
- What is the coordinate of the point that lies halfway between  $A$  and  $D$ ? \_\_\_\_\_. Label this point  $F$ .

## Problem Set:

Number line  $k$  shows 12 units. Use number line  $k$  below to answer the questions.

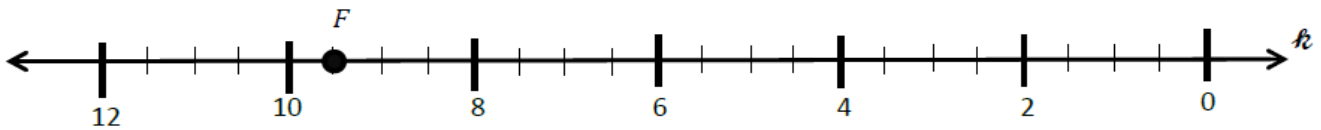

- Plot a point at 1. Label it  $A$ .
- Label a point that lies at  $3\frac{1}{2}$  as  $B$ .
- Label a point,  $C$ , whose distance from zero is 8 units farther than that of  $B$ . The coordinate of  $C$  is \_\_\_\_\_.
- Plot a point,  $D$ , whose distance from zero is  $\frac{6}{2}$  less than that of  $B$ . The coordinate of  $D$  is \_\_\_\_\_.
- What is the coordinate of the point that lies  $1\frac{7}{2}$  farther from the origin than  $D$ ?

## Application Problem:

A landscaper is planting some marigolds in a row. The row is 2 yards long. The flowers must be spaced  $\frac{1}{3}$  yard apart so that they will have proper room to grow. The landscaper plants the first flower at 0. Place points on the number line to show where the landscaper should place the other flowers. How many marigolds will fit in this row?

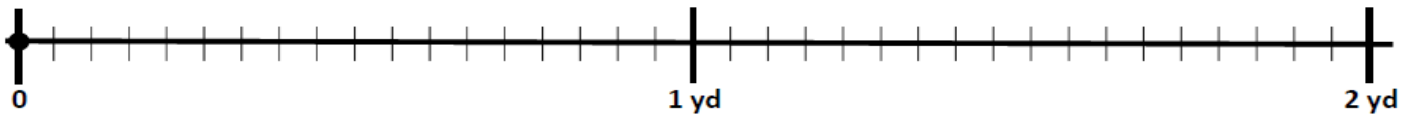

## Exit Ticket

Each shape was placed at a point on the number line  $s$ . Give the coordinate of each point below.

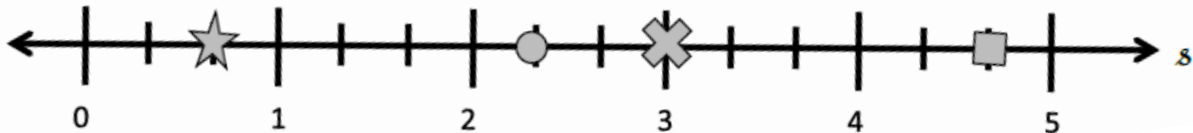

a.  \_\_\_\_\_

b.  \_\_\_\_\_

c.  \_\_\_\_\_

d.  \_\_\_\_\_



**Brighter Choice**  
Charter School for Boys

# **Day # 5**

**Mod 6 Packet 2**

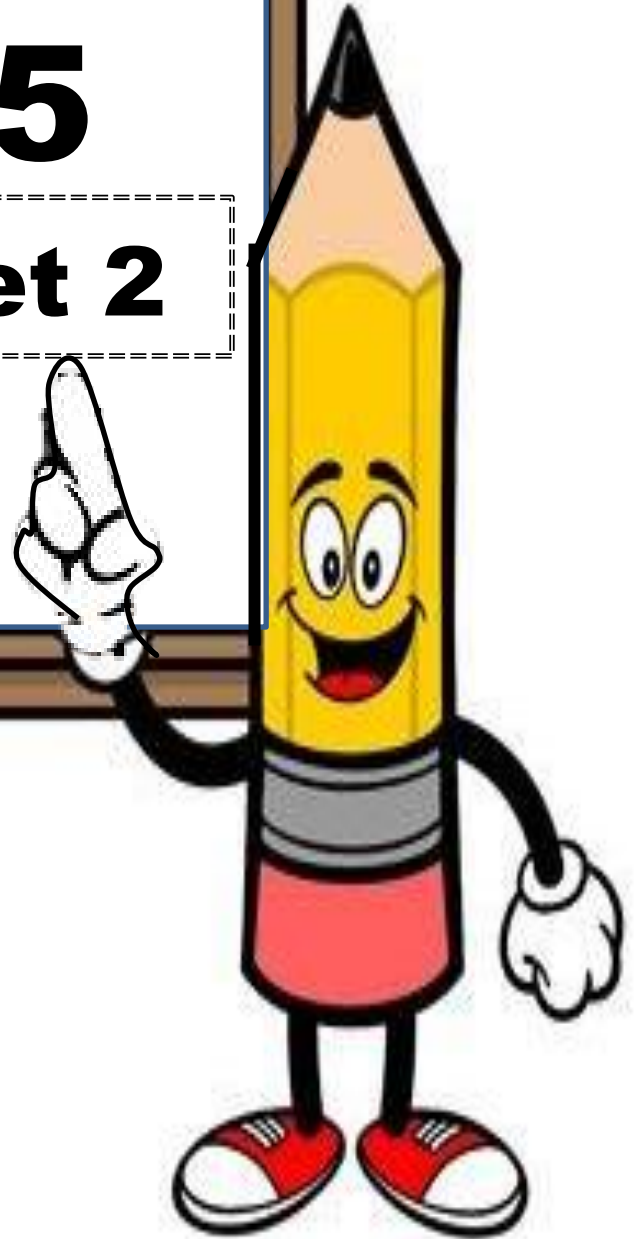

Name: \_\_\_\_\_ Week 33 Day 5 Date: \_\_\_\_\_

BCCS-Boys

Stanford MIT

**Do Now**

Number line  $k$  shows 12 units. Use number line  $k$  below to answer the questions.



- Plot a point at 5. Label it Q.
- Label a point that lies at  $7\frac{1}{2}$  as R.
- Label a point, S, whose distance from zero is 6 units farther than that of R. The coordinate of S is \_\_\_\_\_.

## Input Activity

### Key Terms:

Origin – the \_\_\_\_\_ point (\_\_\_\_, \_\_\_\_)

Y Axis – the \_\_\_\_\_ on a graph that runs \_\_\_\_\_ and \_\_\_\_\_ through \_\_\_\_\_

X Axis – the \_\_\_\_\_ on a graph that runs \_\_\_\_\_ to \_\_\_\_\_ through \_\_\_\_\_

Coordinate Pair - a \_\_\_\_\_ of numbers where the \_\_\_\_\_ number moves on the \_\_\_\_ axis and the \_\_\_\_\_ number moves on the \_\_\_\_ axis y

Ex: (2, 5)

## Problem 1

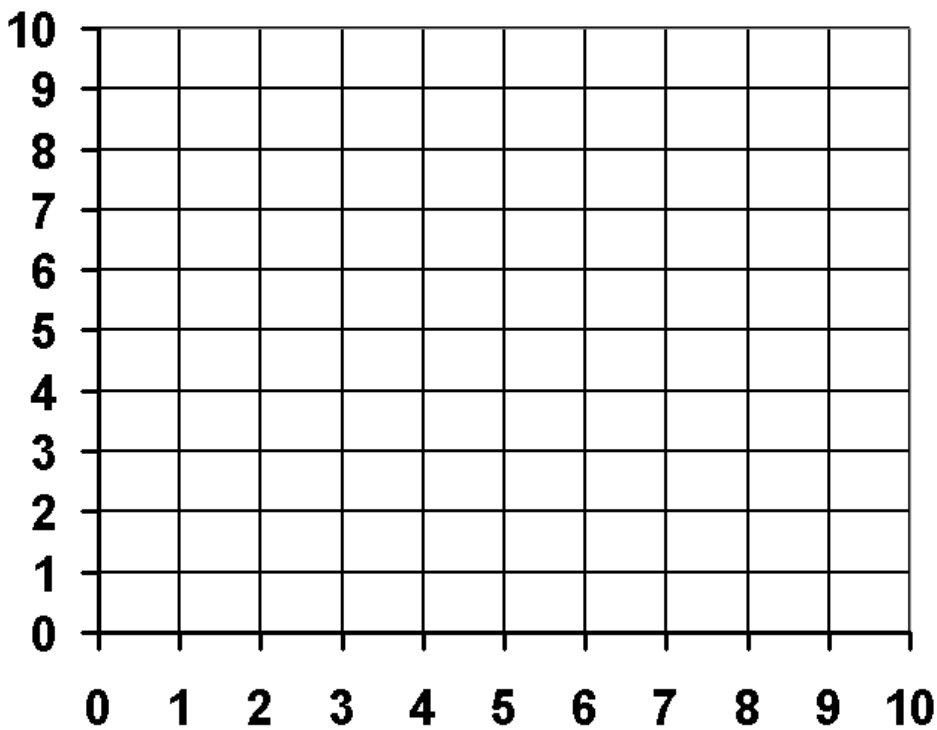

Draw the following shapes on the coordinate plane.

1. A square at  $(4, 3)$
2. A triangle at  $(5, 1)$
3. A circle at  $(0, 7)$
4. A check mark at  $(1, 5)$
5. A star at  $(3, \frac{1}{2})$

## Problem 2

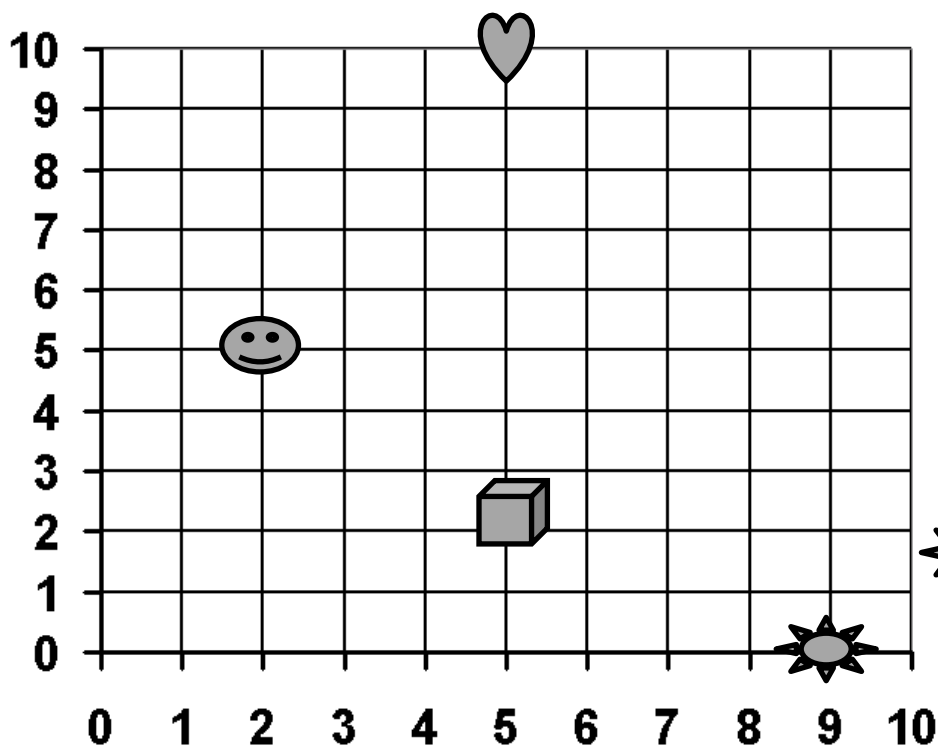

Write the coordinates  
for the following  
shapes:

 = \_\_\_\_\_

 = \_\_\_\_\_

 = \_\_\_\_\_

 = \_\_\_\_\_

Plot the following letters on the coordinate grid above:

C = (3, 4)

L = (1, 0)

U = (8, 8)

T = (0, 0)

E = (5, 6)



### Problem 3:

Use the coordinate plane to answer the following.

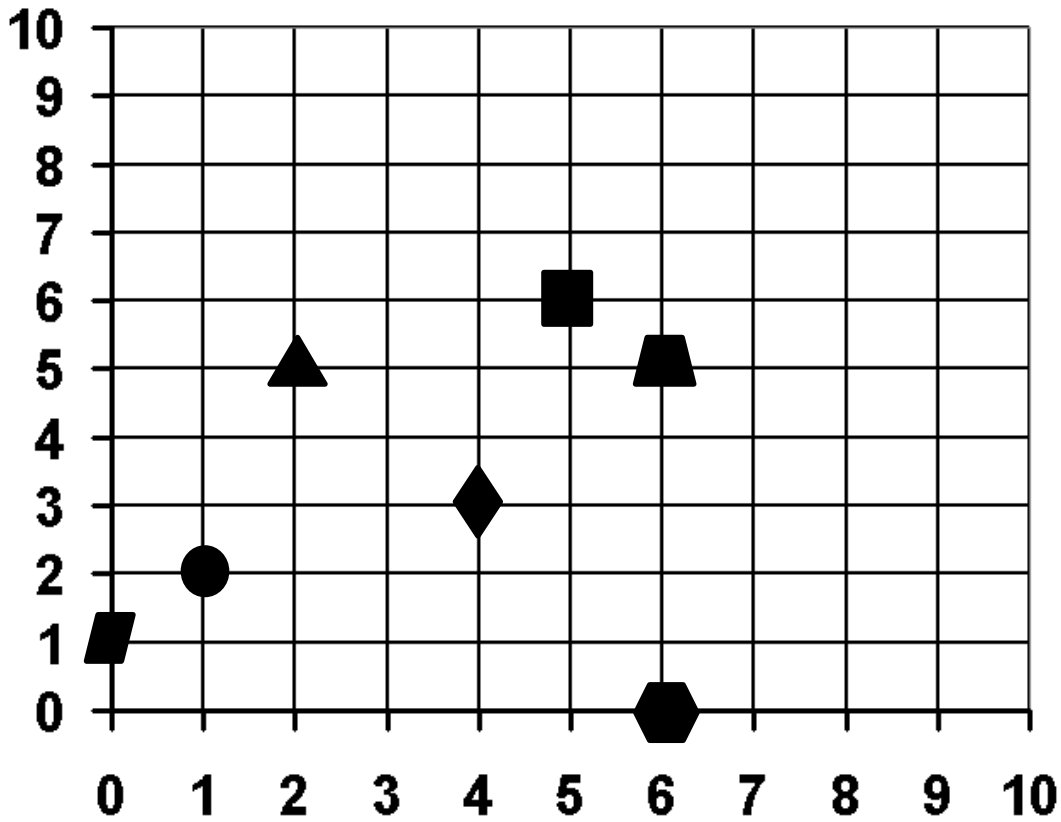

Name the shape at each location.

| <i>x</i> -coordinate | <i>y</i> -coordinate | Shape |
|----------------------|----------------------|-------|
| 2                    | 5                    |       |
| 1                    | 2                    |       |
| 5                    | 6                    |       |
| 6                    | 5                    |       |

Which shape is 2 units from the *y*-axis? \_\_\_\_\_

Which shape has an *x*-coordinate of 0? \_\_\_\_\_

Which shape is 4 units from the *y*-axis and 3 units from the *x*-axis? \_\_\_\_\_

## Problem 4:

Help each animal to reach their food by plotting the points and connecting them with the lines.

$(5, 6), (5, 5), (3, 5), (3, 2), (1, 2)$

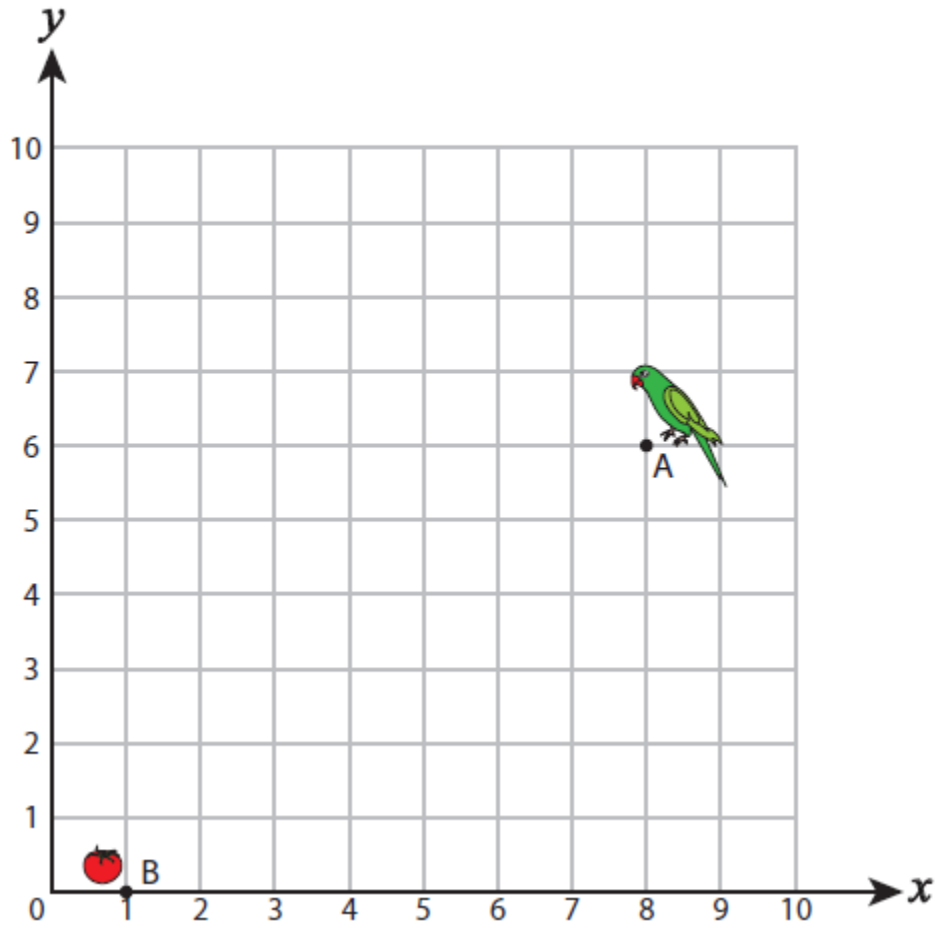

## Problem 5:

$(7, 7), (7, 5), (4, 5), (4, 3), (1, 3)$

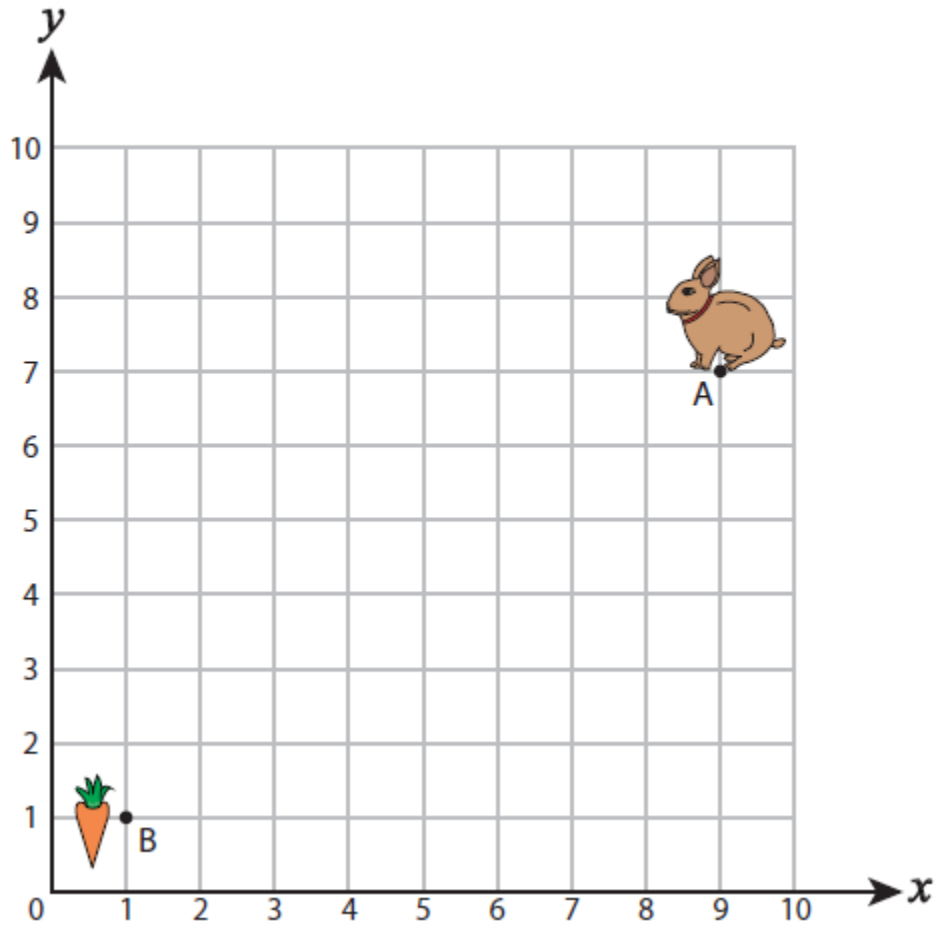

## Problem 6:

A) Plot each point on the coordinate grid.

1) T(3, 3)

2) S(1, 8)

3) H(2, 8)

4) E(6, 2)

5) R(5, 4)

6) L(7, 6)

7) M(3, 1)

8) V(9, 5)

9) P(7, 1)

10) A(4, 7)

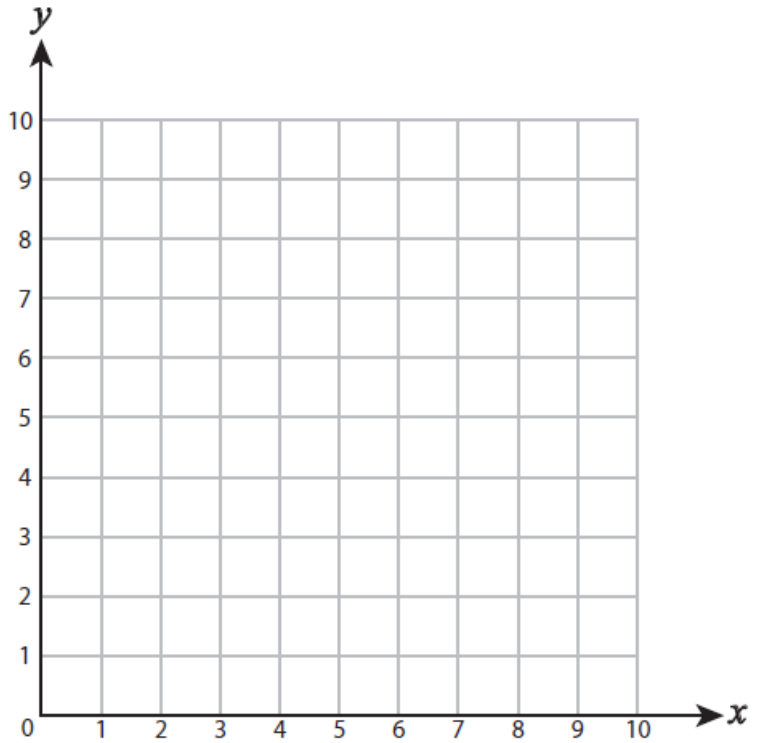

## Problem 7:

B) Draw each shape on the coordinate grid.

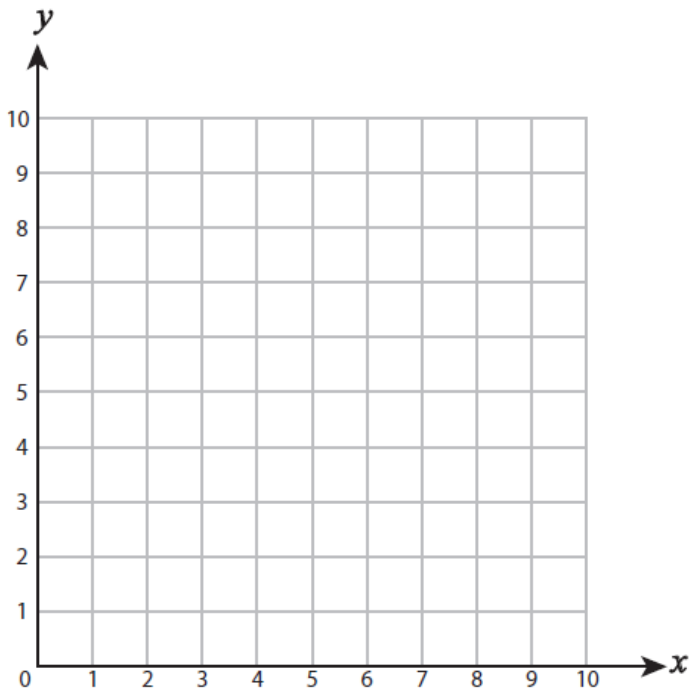

11) Draw ○ at (3, 1)

12) Draw ☆ at (4, 5)

13) Draw □ at (1, 7)

14) Draw △ at (3, 5)

15) Draw □ at (8, 2)

## Problem Set:

Use the coordinate plane to answer the following.

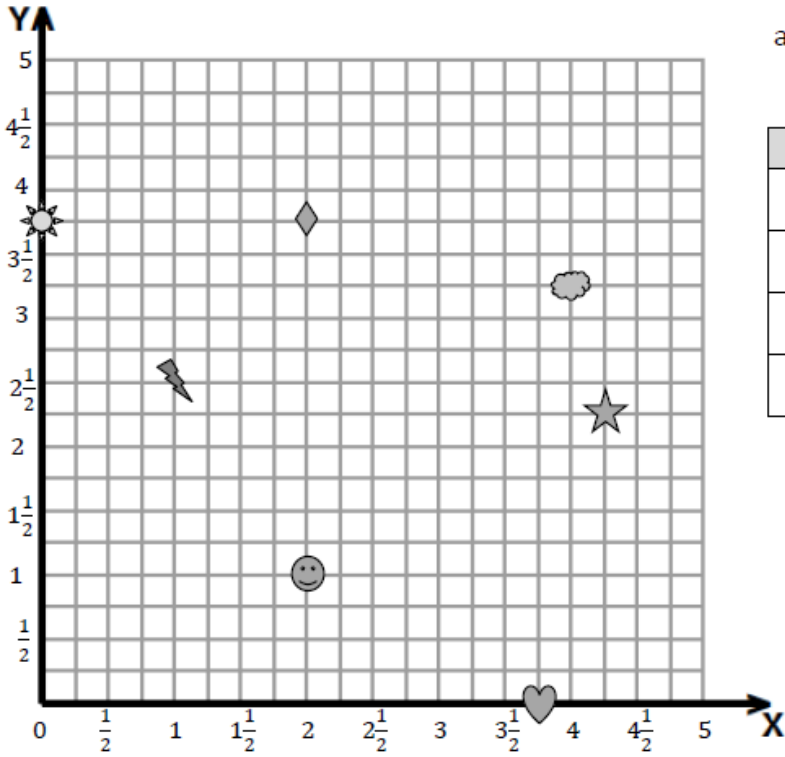

a. Fill in the blanks.

| Shape       | $x$ -coordinate | $y$ -coordinate |
|-------------|-----------------|-----------------|
| Smiley Face |                 |                 |
| Diamond     |                 |                 |
| Sun         |                 |                 |
| Heart       |                 |                 |

b. Name the shape whose  $x$ -coordinate is  $\frac{1}{2}$  more than the value of the heart's  $x$ -coordinate.

c. Plot a triangle at  $(3, 4)$ .

d. Plot a square at  $(4\frac{3}{4}, 5)$ .

e. Plot an X at  $(\frac{1}{2}, \frac{3}{4})$ .

### Application Problem:

Coach Kline collected data on 5 of his baseball players. The points show shoe size and the number of runs scored this week by the 5 players.

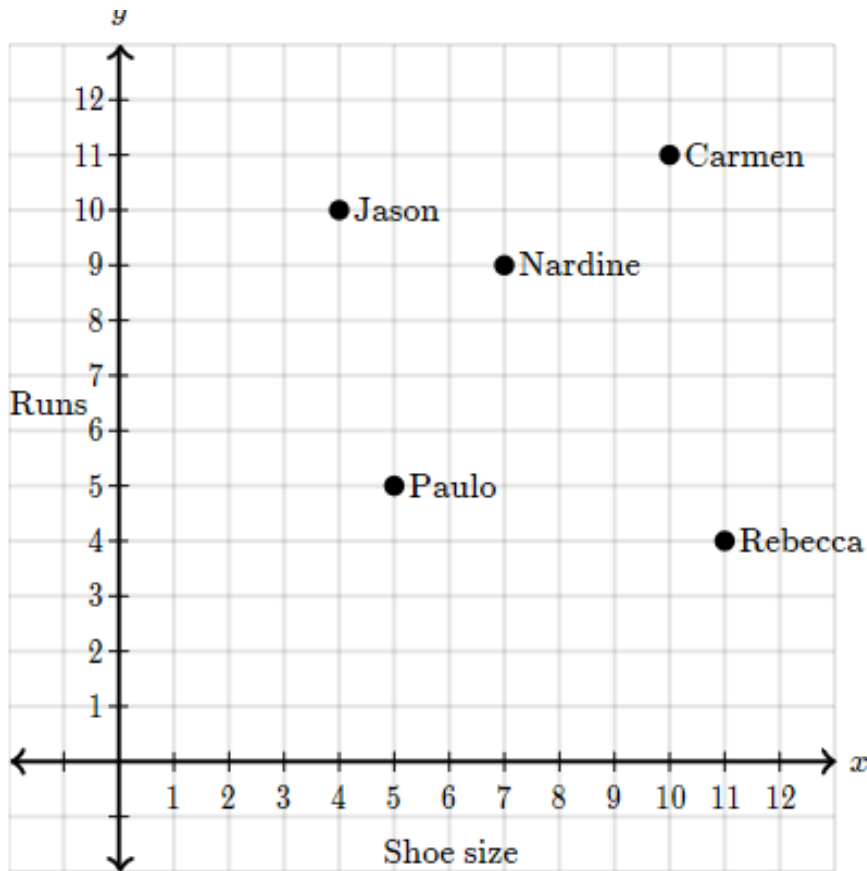

Which player scored the most runs? \_\_\_\_\_

## Exit Ticket

1. Name the coordinates of the shapes below.

| Shape | $x$ -coordinate | $y$ -coordinate |
|-------|-----------------|-----------------|
| Sun   |                 |                 |
| Arrow |                 |                 |
| Heart |                 |                 |

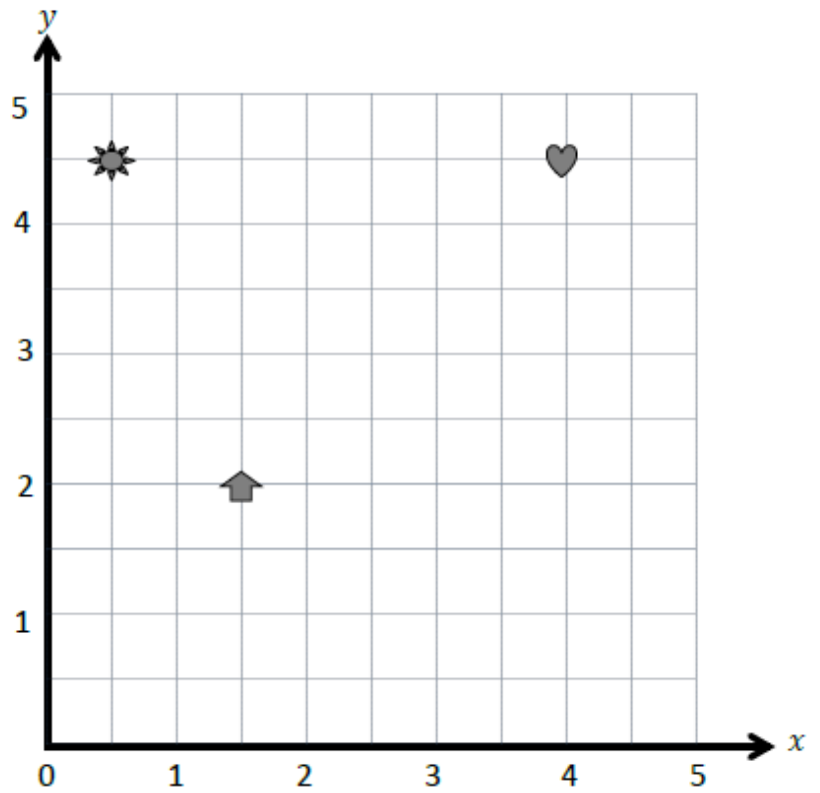

2. Plot a square at  $(3, 3\frac{1}{2})$ .
3. Plot a triangle at  $(4\frac{1}{2}, 1)$ .